

FASTRAK

THE FAST AND EASY DIGITAL TRACKER

THE INDUSTRY STANDARD

The most accurate electromagnetic motion tracking system available, FASTRAK® is the perfect solution for accurately computing position and orientation through space. With real-time, 6 Degrees-of-Freedom (6DOF) tracking and virtually no latency, this award-winning system is ideal for head, hand, and instrument tracking, as well as biomedical motion and limb rotation, graphic and cursor control, stereotaxic localization, telerobotics, digitizing, and pointing. FASTRAK has been the workhorse of the industry since its introduction.

► FEATURES

Real Time

Virtually no latency. Digital Signal Processing (DSP) technology provides 4ms latency updated at 120 Hz. Data is transmitted via USB or RS-232 to the host at up to 115.2 K Baud.

Improved Accuracy and Resolution

Accuracy of 0.03 inches RMS with a resolution of 0.0002 inches per inch makes this the most precise device of its kind.

Range

Standard operational range is 4 to 6 feet; 10 foot range is obtainable. The optional TX4 or Long Ranger™ transmitters allow significantly longer ranges of operation.

Reliable

The pioneer of 3D position/orientation measuring devices, in business since 1970. Real-time self-calibration ensures the unit never needs adjustment.

Multiple Output Formats

Position in Cartesian coordinates (inches or centimeters); orientation in direction cosines, Euler angles, or quaternions.

Angular Coverage

The receivers are all-attitude with no limits.

Drift-Free

Solid state electronics.

Two Solutions in One

FASTRAK is a 3D digitizer and a quad receiver motion tracker, making it perfect for a wide range of applications requiring high resolution, accuracy, and range. By computing the position and orientation of a small receiver as it moves through space, it provides dynamic, real-time measurements of position (X, Y, and Z Cartesian coordinates) and orientation (azimuth, elevation, and roll).

Up to Four Receivers

FASTRAK comes standard with a Microsoft Windows® GUI. With a single transmitter, FASTRAK accepts data from up to four receivers. Because FASTRAK uses proprietary low-frequency magnetic transducing technology, there's no need to maintain a clear line-of-sight between receivers and transmitters.

A/C Magnetics

Quiet and stable, the system is essentially unaffected by facility power grids. Update rates are always maintained, as A/C magnetics offer the best signal-to-noise ratios and incorporate sophisticated digital signal processing capabilities. In addition, adaptive filtering is available as a standard feature.

► APPLICATIONS

Limited only by your imagination!



FASTRAK

COMPONENTS

The FASTRAK system includes a System Electronics Unit (SEU), a power supply, one receiver, and one transmitter. You can easily expand the system's capabilities by adding up to three additional receivers.

System Electronics Unit

Contains the hardware and software necessary to generate and sense the magnetic fields, compute position and orientation, and interface with the host computer via USB, RS-232 or optional RS-422.

10.3 in. (25.9 cm) L x 11.5 in. (29.2 cm) W x 2.2 in. (5.8 cm) H

Source

The source is the system's reference frame for sensor measurements.

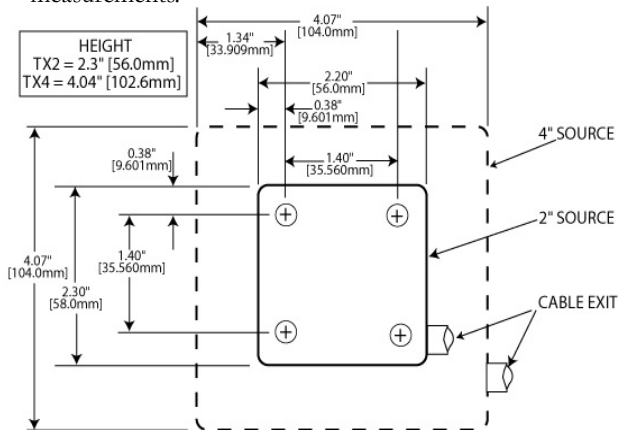

Weight

TX2: 8.8 oz. (250 gm) **Thread size** 1/4" x 20
TX4: 1.60 lbs. (726gm) **Thread size** 1/4" x 20

Sensor

A lightweight, small cube, the sensor's position and orientation is precisely measured as it is moved.

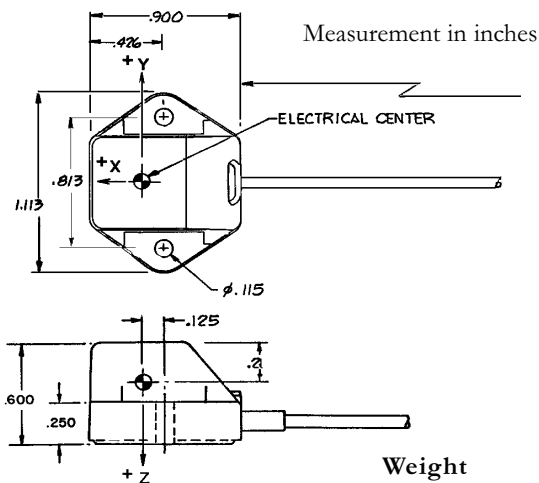

Weight
0.32 oz. (9.1 gm)

POLHEMUS
INNOVATION IN MOTION™

Polhemus is a Good Manufacturing Practices (GMP) Contract Manufacturer under U.S. FDA Regulations. We are not a manufacturer of Medical Devices. Polhemus systems are not certified for medical or bio-medical use. Any references to medical or bio-medical use are examples of what medical companies have done with the products after they have obtained all necessary or appropriate medical certifications. The end user/OEM/VAR must comply with all pertinent FDA/CE regulations pertaining to the development and sale of medical devices and all other regulatory requirements.

SPECIFICATIONS

Update Rate

120 updates/second divided by the number of receivers

Latency

4 milliseconds

Static Accuracy

0.03 inches RMS for the X, Y, or Z position; 0.15° RMS for receiver orientation. The system will provide the specified performance when the receivers are within 30 inches of the transmitter. Operation over a range of up to 10 feet is possible with slightly reduced performance.

Interface

USB; RS-232 with selectable baud rates up to 115.2 K (optional RS-422)

Resolution vs. Range

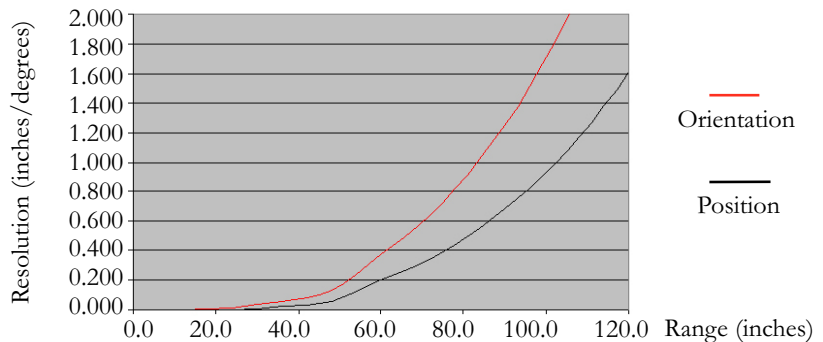

Range (inches)	Position Resolution (inches)	Orientation Resolution (degrees)
12.0	0.00023	0.0026
24.0	0.0030	0.0147
36.0	0.019	0.0558
48.0	0.055	0.1266
72.0	0.346	0.369
120.0	1.605	2.960

Sync Input

TTL and CRT

Software Tools

GUI included

USB drivers for Microsoft Windows® XP/Vista/Win7 included (32-bit and 64-bit). Linux®- open-source application available

Operating Temperature

10°C to 40°C at a relative humidity of 10% to 95%, noncondensing

Power Requirements

15 W, 100-240 VAC, 47-63 Hz

Regulatory

FCC Part 15, class A

CE: EN61326-1: 1997/A1:1998/A2:2001/A3:2003 emission

EN61326-1: 1997/A1:1998/A2:2001/A3:2003 Immunity

* Large metallic objects, such as desks or cabinets, located near the transmitter or receiver, may adversely affect the performance of the system.

www.polhemus.com

40 Hercules Drive • PO Box 560 • Colchester, Vermont 05446-0560
 US and Canada 800.357.4777 • 802.655.3159 • fax 802.655.1439

REGISTERED
ISO9001

FASTRAK is a registered trademark of Polhemus. Microsoft Windows is a registered trademark of Microsoft Corp. Linux is a registered trademark of Linus Torvalds.

Copyright © 2008 Polhemus FT: MS028 Rev. June 2012