

PC-DMIS®

Enterprise Metrology Solutions

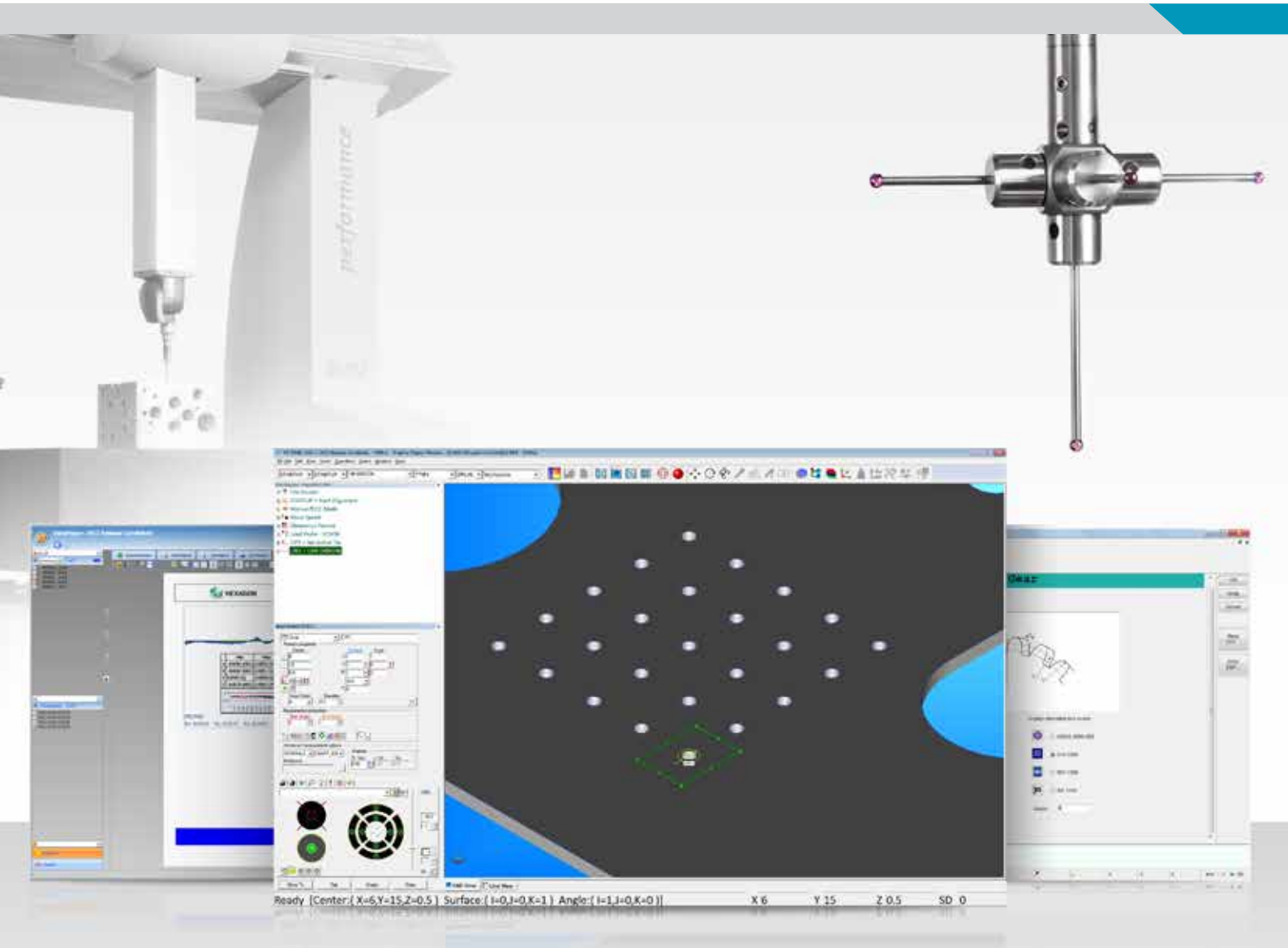

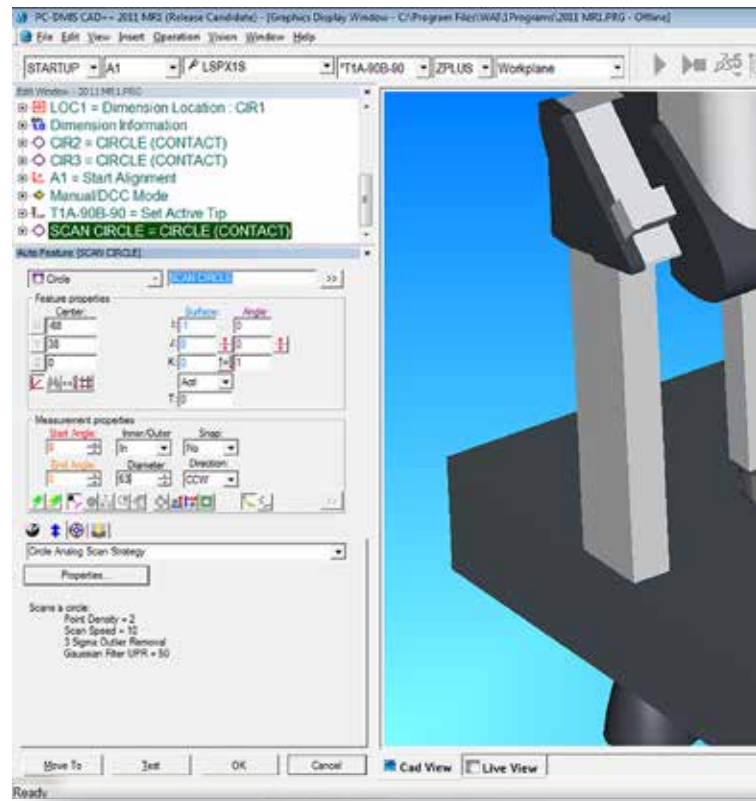
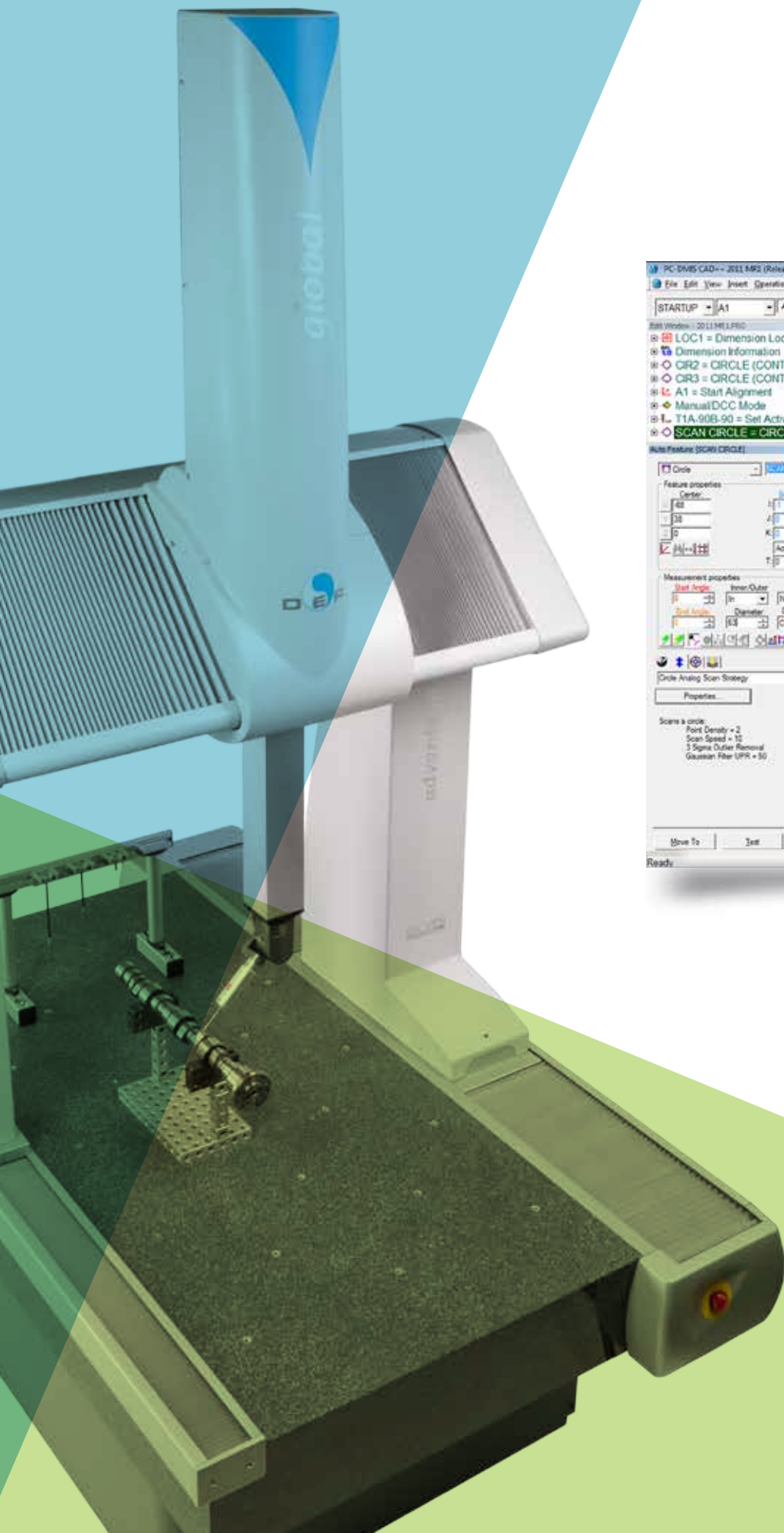

THE ENTERPRISE METROLOGY SOLUTION

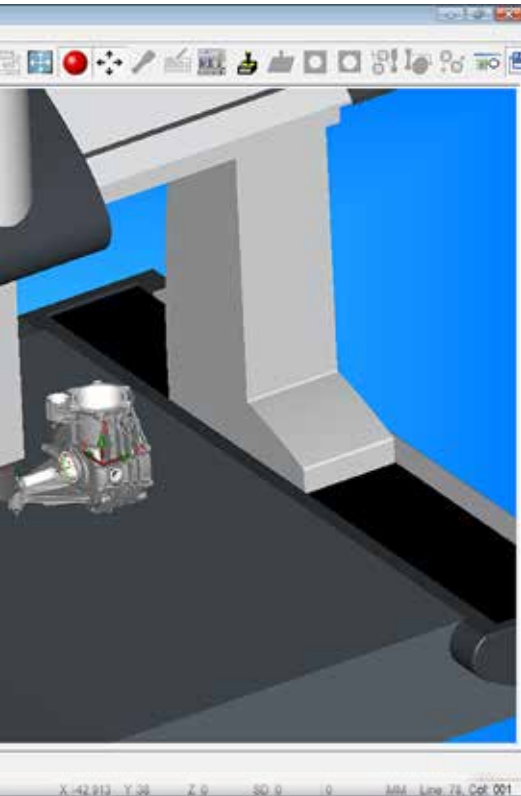

Enterprise Metrology Solutions (EMS) for Process Control and Improvement

With PC-DMIS EMS, a metrology information system can be tailored to meet the specific requirements of any manufacturer. The EMS suite is an integrated group of metrology software products based on a common technology, making it flexible and powerful.

PC-DMIS EMS helps manufacturers build metrology capabilities into multiple stages of the production process from design through production. This interaction at multiple stages improves information availability and allows data-driven decision making that can improve operations.

Data Collection and Reporting Loop – Each PC-DMIS module uses a standardized programming interface to create inspection programs for a wide range of measurement devices. The inspection routine first tells the inspection program how to inspect a part and then how to analyze the generated data. The results are entered into the PC-DMIS reporting engine, which is standard across all version of PC-DMIS. This means that no matter what the data source, users can easily create and understand the reports and take corrective actions.

Data Aggregation – The flexible, powerful PC-DMIS reporting engine provides in-depth information about individual parts. SPC applications allow analysis of the aggregated results from many parts. To meet that need, PC-DMIS EMS offers DataPage+ SPC software. Analysis of data coming from any edition of PC-DMIS is combined real-time into live dashboards and reports of actionable information.

PC-DMIS ENVIRONMENT

Scalable, Flexible Programming Tools

Enhancing Productivity and Quality Through Consistency, Scalability and Flexibility

PC-DMIS EMS provides manufacturers of all sizes a tightly integrated suite of metrology software products. Working seamlessly together, its modules present a consistent look and feel across the full range of measurement operations including inspection planning, program development, part measurement, results analysis, report generation and report distribution.

PC-DMIS EMS Measurement Products

All PC-DMIS measurement modules are based on proven PC-DMIS technology and share a common architecture.

PC-DMIS EMS :

- Supports a wide range of measurement machine configurations and device types, from traditional CMMs to portable devices to machine tools.
- Uses a common programming interface and universal conventions across all editions. This shortens the learning curve and reduces training costs.
- Shares programs among different machines and sensor types with minimal editing.
- Stores measurement data and information in a common database, allowing users to analyze their processes over time and across equipment types.
- Uses a common reporting engine that allows the sharing of report templates among part programs and provides quick customization of existing reports and the generation of new ones.
- Features a Quick Start function that lets users start using their equipment with minimal delay.
- Contains a single set of NIST- and PTB-certified algorithms.

CAD is Key

CAD has always been an integral part of PC-DMIS EMS. Using CAD:

- Designers embed their inspection requirements into the model.
- Programmers develop their inspection routines.
- Measurement software compares results to the model.
- Reports can include the CAD model for easy interpretation.
- Measurement results are used for reverse engineering and additional evaluation.

PC-DMIS EMS products offer a variety of links to CAD. Most include translators for the major neutral CAD standards (IGES, STEP, etc.). For the most exacting applications, Direct CAD Interfaces (DCIs) and Direct CAD Translators (DCTs) are available for all major CAD systems.

A Direct CAD Interface (DCI) works directly on the native CAD model, accessed through the CAD database, without translation and is the most accurate representation of the original. Using DCI occupies a seat on the CAD system.

A Direct CAD Translator (DCT) converts the CAD model directly from its native format into PC-DMIS format without using a neutral translation. It does not occupy a seat on the CAD system.

Different Levels of Capability to Match Different Requirements

Not all parts have the same measurement requirements. To meet these varying requirements, PC-DMIS EMS offers three configurations of most of its measurement products.

PRO meets the basic needs of companies that do not need to integrate CAD and do not need to measure contoured parts. PRO is ideal for newcomers to part programming without CAD experience. Features developed to streamline the process include “guess” modes for automatically identifying the type of features measured and Quick Start routines that automate many basic metrology functions. It also offers a rich set of programming, analytical and reporting tools.

CAD is ideal for makers of prismatic parts that want to integrate CAD into their inspection operations. It expands on the capabilities of PRO by letting customers program and inspect parts using CAD models ranging from simple 2D blue prints through full 3D solid models. CAD allows full use of all PC-DMIS EMS CAD-linking technologies. It features an intuitive GUI and includes power wizards that guide engineers through the programming process. CAD includes a library of kinematic machine models for simulation and allows users to add new ones if required.

CAD++ lets users measure the most complex parts. It includes all the capabilities of CAD and adds the ability to measure intricate, contoured surfaces including thin-walled sheet metal, plastic, blades, dies and molds. CAD++ supports numerous scanning devices and applications and includes algorithms for managing large amounts of data. It links to CAD, allowing users to compare measurement results directly against models for unsurpassed speed and accuracy. It is feature rich, yet easy to use.

Enhancing Productivity Through Off-Line Programming

For shops where machine time is a valuable commodity, PC-DMIS offers off-line licenses of the CAD and CAD++ configurations. Offline versions allow the inspection machines to be used primarily for measuring parts and not for part programming. An offline license allows users to develop, test and debug inspection routines off-line using CAD models. Simulated program execution is possible on accurate kinematic models of their machines, so programs can be tested before they are ever used on a physical machine.

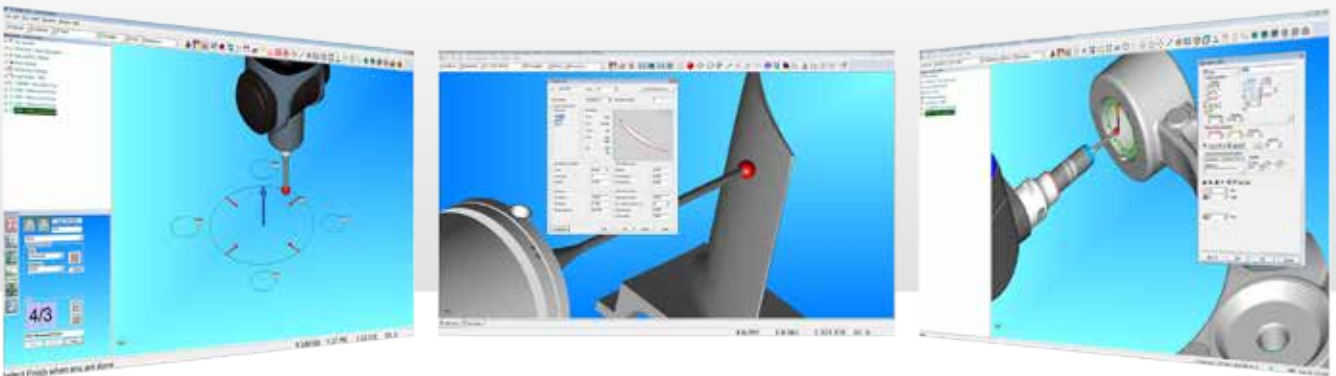

PC-DMIS CMM

The Foundation of Enterprise Metrology

The programming, evaluation and graphics engines from PC-DMIS CMM form the foundation that all other PC-DMIS software versions are built on, making it easy for customers to build an integrated enterprise metrology strategy on a common software platform. PC-DMIS CMM is available as standard software on all new Hexagon Metrology brands of coordinate measurement machines. It is also easy to upgrade on existing machines, including most non-Hexagon CMMs. PC-DMIS CMM offers fully supported migration paths for many existing Hexagon Metrology legacy software products.

Flexibility and Ease of Use

PC-DMIS CMM is powerful and flexible, making it easy for both programmers and operators to use to their advantage.

Users can:

- Make quick checks or program complex parts using a powerful, flexible graphical user interface.
- Configure and calibrate probes of all types quickly and accurately using a built-in set of probe management functions.
- Edit probe paths, add and delete hits, insert clearance moves and modify measurement parameters with the click of a mouse.
- Utilize graphical controls to modify part representations and set measurement parameters.
- Embed full-screen pictures and videos into operator instructions.
- Measure complex, thin-walled features quickly with a rich set of pre-defined routines.
- Develop tailor-made, high-level language routines and configure toolbars and menus according to specific needs and preferences.

Linking to CAD

PC-DMIS CMM was the first to integrate CAD in the measurement process. Ongoing development improves those links and helps synchronize the operations of design, manufacturing and quality. CAD functions include:

- Manipulating models by mirroring, adding layers, removing, hiding and changing entities and adding grids.
- Using either Direct CAD Interface (DCI) or Direct CAD Translator (DCT) technologies or using neutral formats like IGES and STEP.
- Detecting potential collisions by combining CAD part models with CAD models of both holding fixtures and machines.
- Automatically modifying the CAD orientation to align with the probe direction.
- Importing even the largest CAD files using a powerful state-of-the-art graphics engine.

Data Analysis

Users of metrology software make important decisions based on their measurement software and the need to be confident that the results are repeatable and accurate. PC-DMIS CMM:

- Conforms to international (PTB and NIST) standards for CMM software.
- Supports GD&T according to ASME Y14.5, ISO 1101 and ISO 8015.
- Supports Custom User Defined GD&T Datum Reference Framing.

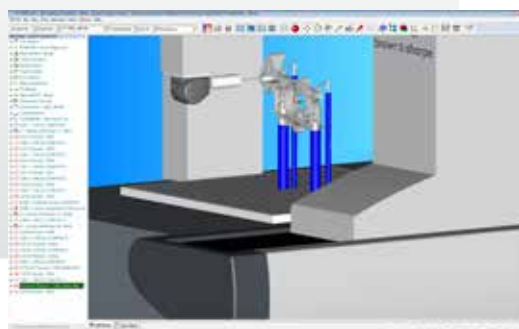
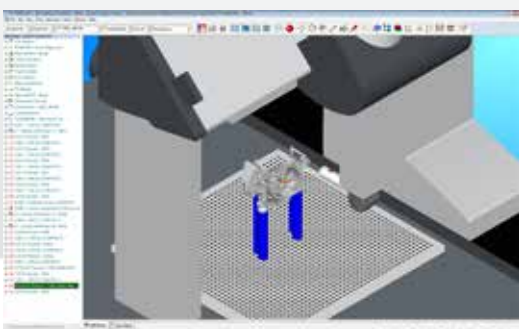

Powerful Reporting Tools

The purpose of measuring parts is to generate meaningful, actionable information. PC-DMIS CMM includes the universal set of full-featured reporting tools common to all editions of PC-DMIS. Capabilities include:

- CAD models incorporated into reports for easy interpretation. Graphical representations of measured features can be used when CAD is not available.
- Generating inspection reports using either pre-defined templates or customized formats.
- Reporting results directly with DataPage+ SPC analysis and report distribution.
- Reporting measurement data to third-party software packages for additional analysis and processing.

Support for 3D Scanning

Improvements in technology have made 3D scanning an important part of CMM measurement. PC-DMIS supports a wide range of devices and a full set of capabilities. These include:

- Quickly defining scan paths and extracting nominal values and vectors.
- Scanning and measuring contoured and sheet metal parts using a wide range of probes including touch trigger, analog and laser.
- Employing a wide variety of scanning methods and customized scanning techniques and templates.
- Automatically scanning and reverse engineering unknown surfaces and features.
- Using manual CMMs to scan both thin-walled and contoured parts.



PC-DMIS PLANNER

Linking Design to Inspection

Planning for Inspection

The need for inspection is built into the manufacturing process. However, many organizations have discovered that the process of translating the design intent of a CAD model into a set of inspection instructions isn't built into the software. PC-DMIS Planner software is a groundbreaking, stand-alone application that automates the flow of information between the virtual world of the design department and the real world of the engineering departments responsible for part manufacture. It creates a bi-directional link between CAD models and their related inspection programs.

Building Inspection Requirements Into CAD Models

The communication of design requirements and modifications from the design department to the shop floor is often a haphazard proposition. It can include marked-up drawings, endless meetings, numerous phone calls and costly errors. PC-DMIS Planner eliminates this disconnect by automating the communications process.

Ensuring Dimensional Integrity From Design Through Manufacture

Today, design engineers do most of their work on 3D CAD systems where they design "perfect" parts. Manufacturing processes produce parts that are as close as possible to the perfect reference part. Quality can interface with design in the following ways:

Product Design/CAD Database - Once a designer has stored a model in the CAD database, it becomes available to users of the EMS system for the development of inspection plans. PC-DMIS EMS, including PC-DMIS Planner, with its optional Direct CAD Interfaces (DCIs) and Direct CAD Translators allows inspection departments to base their plans on the most accurate versions of the CAD models.

Quality Control Planning and Process Design - PC-DMIS Planner lets designers electronically annotate their 3D models by defining features, datums and dimensions. It can create inspection plans from the annotations for a variety of measurement devices. PC-DMIS Planner allows users to create synchronized bi-directional communications links between CAD files, inspection plans and part programs, ensuring that parts are evaluated according to most up-to-date specifications.

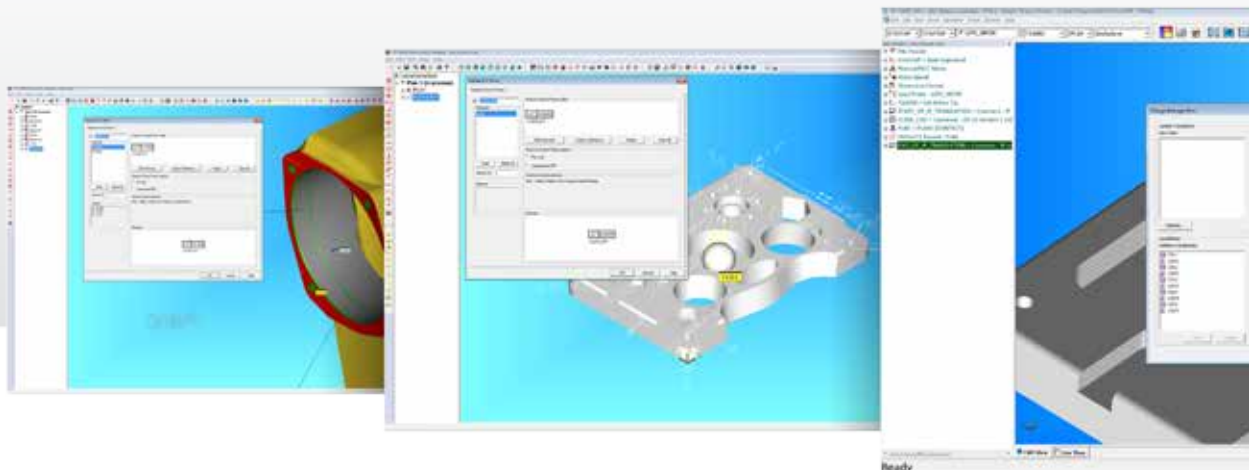

PC-DMIS Planner was specifically developed for design engineers

Key advantages include:

- Elimination of marked-up drawings. All design intent (datums, dimensions, tolerances, etc.) is embedded in the CAD file to create inspection plans.
- Utilization of CAD files translated from standard formats (i.e. IGES, STEP) or use the PC-DMIS Direct CAD Interface (DCI) or Direct CAD Translator (DCT) technologies to work on files in specific CAD formats.
- Production of inspection plans that are independent of any inspection equipment type and usable by any device running PC-DMIS.
- Generation of basic PC-DMIS part programs automatically from inspection plans using default parameters that ensure consistent feature measurement.
- Exploitation of PC-DMIS' tools for optimizing probe paths and inserting clearance moves to produce efficient part programs.

Tracking Changes

Changes to CAD models and inspection requirements are a constant in any manufacturing operation. Communicating these changes to the quality assurance organization is crucial to success. PC-DMIS and PC-DMIS Planner work jointly to track changes in original CAD files and provide tools to keep the associated inspection plans and part programs in sync. This process is automated, greatly reducing errors.

PC-DMIS and PC-DMIS Planner both incorporate change manager tools. The change manager tool in PC-DMIS Planner synchronizes CAD models and inspection plans. The change manager tool in PC-DMIS synchronizes inspection plans and inspection programs.

PC-DMIS Planner Change Manager:

- Compares an inspection plan to its CAD model and automatically recognizes any differences between them.
- Highlights differences between models and plans and allows the user to make changes or ignore them.

PC-DMIS Change Manager:

- Identifies differences between inspection plans and their associated part programs.
- Allows users to make changes based on the differences between plans and programs or ignore them.
- Works with PC-DMIS Planner Change Manager providing easy-to-use tools for quickly updating part programs based on changes to either the CAD file or inspection plan.

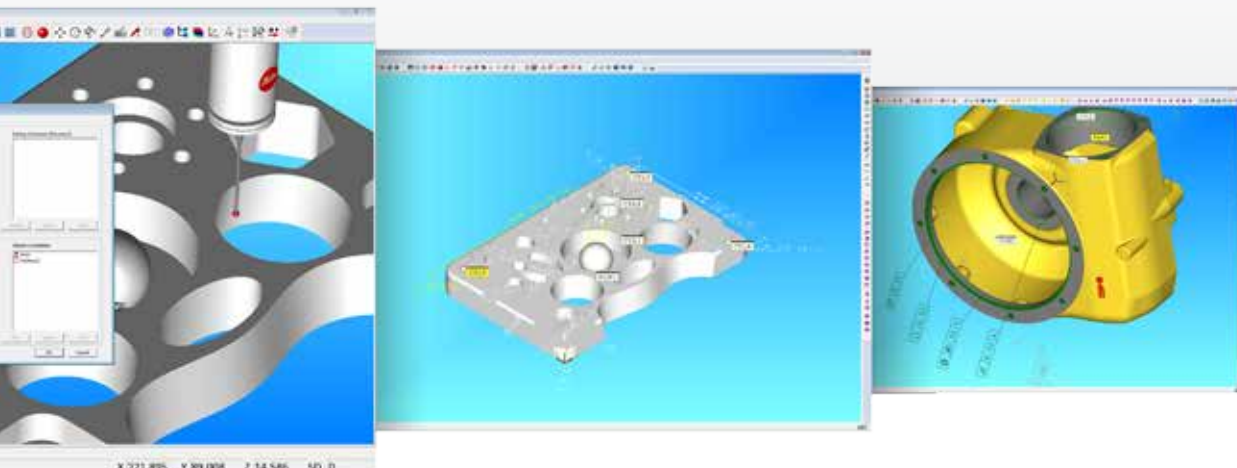



HEXAGON
METROLOGY



PC-DMIS VISION

A New Take on Vision Metrology

Bringing the Power of PC-DMIS to Vision Measurement

PC-DMIS has long set the standard for CAD-based CMM software. PC-DMIS Vision brings these capabilities and a host of new ones to the world of vision measurement.

PC-DMIS Vision provides vision metrologists with the same tools long available to users of PC-DMIS CMM. These include powerful methods for measuring 3D parts on vision systems. It also makes short work of measuring 2D parts, the traditional application of vision measurement. In addition, PC-DMIS Vision users have access to the complete EMS range of additional analytical and reporting capabilities.

Putting CAD in Vision Measurement

PC-DMIS pioneered the incorporation of CAD into metrology software. PC-DMIS Vision adapts this fundamental capability to the unique demands of vision metrology. Allowing CAD models to be used as perfect “master parts” for programming and inspection purposes greatly improves both programming and inspection throughput. PC-DMIS Vision’s CAD-based capabilities:

- Perform both part-to-CAD and advanced GD&T analyses not possible with traditional vision software.
- Extract information from the CAD model, eliminating errors of data interpretation and input.
- Increase part programming throughput up to 75% by using 3D CAD models to develop, check and edit inspection routines with point-and-click simplicity.
- Import CAD models and export measurement results in a wide range of industry standard and vendor-specific formats.
- Develop programs off-line with an optional module that simulates all aspects of the measurement process. Switch between the CAD view and a CADCamera® view that accurately simulates not only a camera image but also the illumination and magnification parameters.
- Draw on PC-DMIS’ feature based programming functions to simplify both feature creation and editing.
- Include standard PC-DMIS reporting toolset allowing CAD images to be embedded in inspection reports for ease of reference.

Advanced Features for Vision Metrology

PC-DMIS Vision also includes a flexible and powerful toolset for controlling cameras, illumination and sensors on vision systems. Because the programming environment is identical to PC-DMIS CMM, anyone familiar with that version can easily make the transition by learning the vision specific operations.

PC-DMIS Vision Includes:

- Complete portability of part programs. Programs will run on different vision machines, or even other machine types such as CMMs, with little or no modification.
- The revolutionary patent-pending Multi-Capture function automatically finds all features that fit within the field of view and simultaneously measures them, even if the features are of differing types. Multi-Capture then drives the camera to the next field of view and repeats the process. For parts with dense clusters of features, this can increase inspection throughput by as much as 70%.
- A Sensi-light function assists users in selecting correct illumination settings.
- Feature-based programming not only simplifies the creation of features but also their editing.
- Tools automatically adjust critical measurement parameters like lighting and magnification.
- A Teach Mode Execute (TME) function that halts program execution when a problem is encountered and lets users reprogram features on the fly.

Data Aggregation

PC-DMIS Vision and EMS let you merge vision measurement data with other data taken within an organization into a consolidated metrology database. This facilitates analysis with measurement data collected from multiple device types.

PC-DMIS PORTABLE

Bringing Metrology to the Shop Floor



Getting the Most From Portable Measurement

Portable measurement devices have revolutionized the way manufacturers use metrology. Measurements tasks and analysis can take place on the shop floor where it has the most impact. Software that achieves optimal performance from portable measurement equipment is essential.

PC-DMIS Portable is a highly sophisticated metrology software tightly integrated with portable metrology tools such as portable measuring arms, laser trackers and total stations. Market leading capabilities deliver peak performance at the point of production.

A Full Range of Capabilities

Whether the task is inspection, building virtual assemblies or solving engineering problems, PC-DMIS Portable gets the job done quickly and efficiently. Special user interfaces tailored for specific device types arrange all the commonly used controls and functions for speed and ease of use.

Integrating Portable Measurement Into Enterprise Metrology Solutions

PC-DMIS Portable is a part of the EMS suite of metrology software products. By running PC-DMIS Portable on their portable measurement devices, companies of all sizes and industries can integrate their portable measurement operations into true metrology systems.

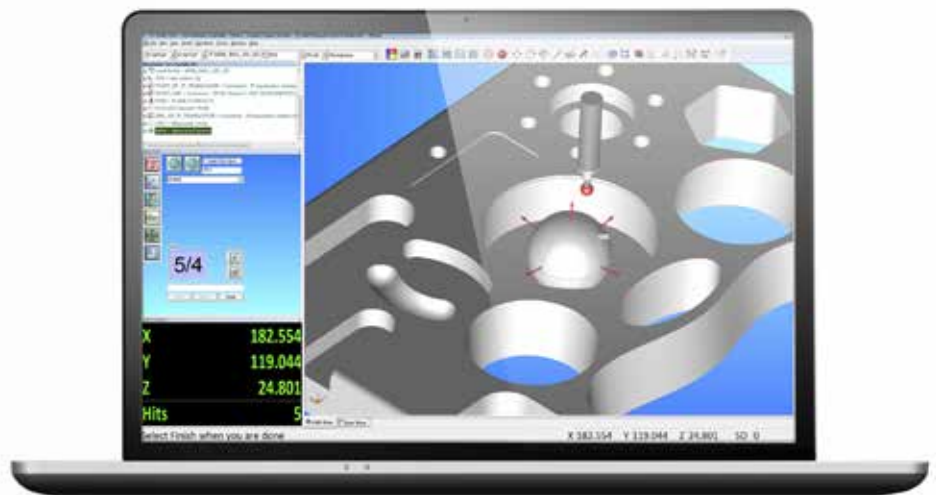

PC-DMIS Portable:

- Minimizes the learning curve with a quick-start GUI that lets programmers and operators make full use of their machines' most frequently used capabilities. When needed, PC-DMIS' full capabilities are only a couple of mouse clicks away.
- Features CAD capability which allows inspection routines to reference the CAD during inspection or programming tasks.
- Has automatic programming which allows part programs to be created during a live inspection for recall and later use.
- Finds the correct nominal data automatically from CAD while the part is measured. There is no need to query the model before measurement.
- Protects part programs from unauthorized changes with a Protected Mode that allows operators to run programs but not modify them.
- Provides device-specific user interfaces that organize the software's capabilities so all controls for a particular device are readily available when the software is used.
- Displays guided inspection prompts through measuring sequences with text, graphics and even movies. Prompts guide the user by indicating on the CAD model which feature to inspect next, increasing throughput and minimizing errors.
- Eliminates part-programming bottlenecks with off-line capabilities. Using PC-DMIS Offline, programmers can develop inspection sequences independent of the inspection device. This reduces the time taken for inspection or adjustment on-site and minimizes downtime.
- A full set of PC-DMIS reporting options are available ranging from simple text-based outputs to fully annotated graphical presentations based on a part's CAD model.
- Features industry-leading GD&T algorithms in support of ISO and ANSI standards. PTB certified.



PC-DMIS NC

On-Machine 3-Dimensional Metrology

PC-DMIS NC brings the proven technologies of PC-DMIS to the work of on-machine part setup and validation. It is the first true metrology software package for CNC probing systems. It lets machinists take full advantage of onboard CNC probes and allows manufacturers to make on-machine metrology an integral part of their advanced manufacturing and quality assurance systems. With PC-DMIS NC, it is no longer necessary to struggle with the difficulties and limitations of macro languages and the restricted capacities of their algorithms. PC-DMIS NC develops inspection programs in a sophisticated and easy-to-use programming environment and uses PTB-certified algorithms to evaluate measurement data.

CAM Software for CNC Probing

Historically, machine tool probes, with their restricted functionality and limited macro languages, have been of minimal use for all but the simplest applications. Now, PC-DMIS NC gives machine tool probe users access to all the programming and data management capabilities of a full-featured CMM measurement package. Capabilities include:

- PC-DMIS NC offline allows development and testing of NC inspection routines on 2D and 3D CAD models. Because all work takes place off-line, the programming process has zero impact on machine utilization.
- Inspection routines download to NC controllers automatically.
- Inspection paths can be built in standard G and M formats. Machine operators do not have to learn a new language or a special measurement application.
- Collection and evaluation of measurement data as it becomes available without operator intervention.
- Support for multiple machine tools of varying controller types and axis configurations.
- Shared inspection routines with other PC-DMIS EMS software products to ensure correlation of measurement results.

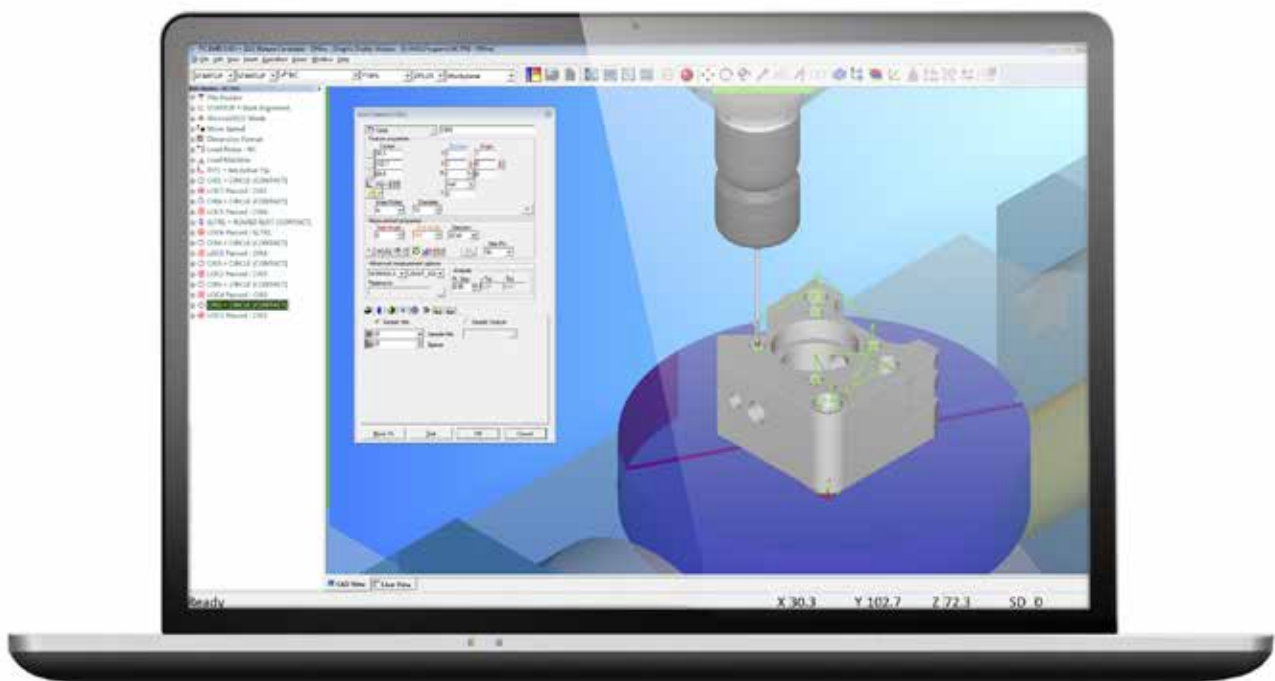



Process Benefits include:

- Making quick checks during setup and eliminating most programming and setup faults before they become expensive scrap and rework mistakes.
- Eliminating the delays and errors inherent in manual inspection.
- Checking work offsets by measuring selected part geometry, then fine tuning and automatically updating them.
- Aligning and measuring the most complex contoured parts and tooling easily.
- Evaluating parts on the machine during machining cycles, especially those that cannot easily be removed for inspection.
- Utilization of PC-DMIS NC as an evaluation tool to gain a full understanding of process strengths and weaknesses at each incremental step.
- Checking measurement results directly against the CAD model using a powerful 3D analytical engine and advanced fitting algorithms.
- Tracking and automatically modifying cutting programs to compensate for changes in tool characteristics.
- Increasing the measurement accuracy with unique advanced calibration and compensation routines.

Information for Process Control

PC-DMIS NC monitors operations while the parts are still on the machine, making real time evaluation possible. PC-DMIS NC compares measured features to the CAD model for fast and accurate analysis, with a monitor mode that allows quick go/no-go part checks. A built-in SPC module allows effortless tracking and evaluation of processes over time.

Eliminating Scrap through Enterprise Metrology Solutions

Lean manufacturing is all about eliminating waste in all forms, and PC-DMIS NC is all about lean manufacturing. It brings the world's leading measurement technology directly to the shop floor. The CNC machine becomes an integral part of a metrology system dedicated to eliminating scrap, minimizing rework and saving money. In today's competitive environment, anything less is not enough.

DATASUITE+ SPC

Powerful SPC Tools for Metrology



Statistical Process Control for Successful Manufacturing

Effective deployment of Statistical Process Control (SPC) software enables processes to be closely monitored in real time. Benefits of SPC include quick identification of small problems before they become major issues and the ability to analyze and improve processes over the long term.

The all-new DataPage+ SPC package is the result of applying more than 20 years of experience in the development and application of SPC software for metrology applications. It provides companies of all sizes with a scalable, flexible SPC toolkit that can be custom applied to specific requirements.

Turning Measurement Data Into Actionable Information

DataPage+ is an integrated set of tools for the real-time capture and analysis of measurement data. It turns this data into actionable information and automatically formats it for its intended audience. Information is delivered by the fastest possible means. The result is a responsive SPC system that can help resolve problems quickly, minimize down time, reduce scrap and vastly improve product quality.

DataPage+ has two available configurations, DataPage+ for the desktop and a Web Reporting Suite, both providing identical SPC functionality but with different access and licensing configurations, to meet the requirements of all sizes of organizations ranging from small shops to the largest multi-nationals.

DataPage+ Traditional Licensing — DataPage+ uses a traditional one computer-one license plan; designed for single facility or small company use. Multiple systems can access and share a single SPC results database.

Web Reporting Suite — A client-server system where a single SPC database is accessed via a network-licensing model over a web browser. This configuration is ideal for multiple site and enterprise-level implementations.

DataPage+ is a stand-alone SPC package for analyzing data coming from multiple types of measurement devices and multiple types of software. It features:

- Integration with the PC-DMIS reporting engine for easy data transfer.
- A customizable Dashboard view which allows multiple processes, features or other characteristics of interest to be monitored in real time.
- Multiple templates which allow report organization into the most appropriate format for the intended audience, such as production, management or engineering.
- Monitoring in real-time as measurements are made, providing immediate part quality feedback to the shop floor.
- The ability to track tool wear to notify operators when adjustments are needed.
- A rich toolkit for operators, engineers and managers to investigate manufacturing problems, aiding in root cause analysis and implementing process improvement initiatives.
- The ability to merge data from PC-DMIS or any other measurement software program and merges that data into a single SQL database.
- Scalability to meet changing customer needs by employing robust database architecture.
- Automatic data output in Excel formats.
- An optional CAD reporting module to merge models with measurement results for easy to understand visual interpretation of data.



WEB REPORTING SUITE

Quality Reporting Systems Via the Internet

Meeting the Reporting Needs of Many Users

Web Reporting Suite is an enterprise-wide reporting system that works in conjunction with the PC-DMIS software products and its DataPage+ reporting package. It is a web-enabled, integrated reporting system that captures and analyzes measurement data in real time. It then automatically generates and distributes the resultant reports in the right format to the right place at the right time.

Using the Web and Closing the Loop

Web Reporting Suite is a true web server application. It resides on a centralized server and uses a concurrent network-licensing model. Companies do not have to install software on each user's computer and they do not have to buy licenses for each. Instead, they buy a pool of sharable licenses. Users can access the data either via intranet or Internet connection from any web browser. Because the connection is bi-directional, data flows directly from measurement devices to the database eliminating data handling issues.

DataPage+ Web Reporting Suite:

- Monitors both internal and supplier production processes by transmitting measurement data directly from the shop floor to the metrology database for immediate analysis. The software immediately notifies operators and engineers of both actual and potential problems.
- Plans for validation using PC-DMIS Inspection Plans to pre-define report formats (templates) before any parts are measured. The reports are instantly available once part measurement begins.
- Delivers reports using a built-in Report Delivery Scheduler. The software automatically sends the specific reports when they become available.
- Provides authorized users a report viewer application that allows them to view reports from anywhere using the Internet.
- Improves processes using PC-DMIS DataSuite+ SPC software. DataSuite+ provides a full set of capabilities for managing large amounts of data and analyzing processes and their capabilities.
- Generates easy-to-understand graphical reports by annotating the CAD model with dimensional information.

EMS Software for Enterprise Reporting

DataPage+ and the Web Reporter Suite are part of the EMS family of metrology products. They address the needs of customers who need to integrate web technology into their metrology reporting systems. In keeping with the EMS philosophy, it is flexible, scalable and powerful in both operation and configuration.

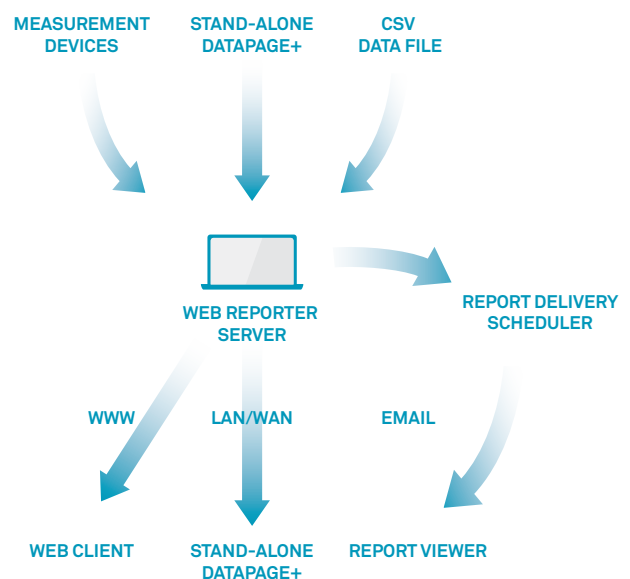

PC-DMIS RESHAPER

Software for Point Cloud Analysis

Powerful Tools for Point Clouds

PC-DMIS Reshaper offers a specialized set of tools to create high-quality 3D models for reverse engineering, CAD-comparison or part duplication. Reshaper allows either live connection to a measuring device for data collection or functions as a stand-alone application for processing, meshing and editing of 3D point cloud data. Reshaper can be used to create high-quality, accurate digital models quickly. Using advanced algorithms, it is capable of processing the largest point cloud files in moments.

PC-DMIS Reshaper Features:

Point Cloud Processing

- Manage the largest point clouds easily
- Manipulate, edit, merge and separate point clouds
- Easily register, align and best fit clouds
- Remove extraneous data and reduce noise

Meshing Capabilities

- Reduce and optimize polygon mesh data
- Fill holes to bridge missing data
- Optimize meshing along high curvature areas
- Deform shapes in 3D for mesh modification

3D Control and Inspection

- Import files in IGES and STEP formats
- Compare surfaces of contours
- CAD-comparison mapping of surfaces in color with variable scales and movable data flags

Reverse Engineering

- Model parts in 3D for further CAD design or adaption
- Create a legacy or golden part where no CAD or part drawing exists
- Analyze competitive parts and products
- Preserve 3D records of artifacts for archival or historical purposes

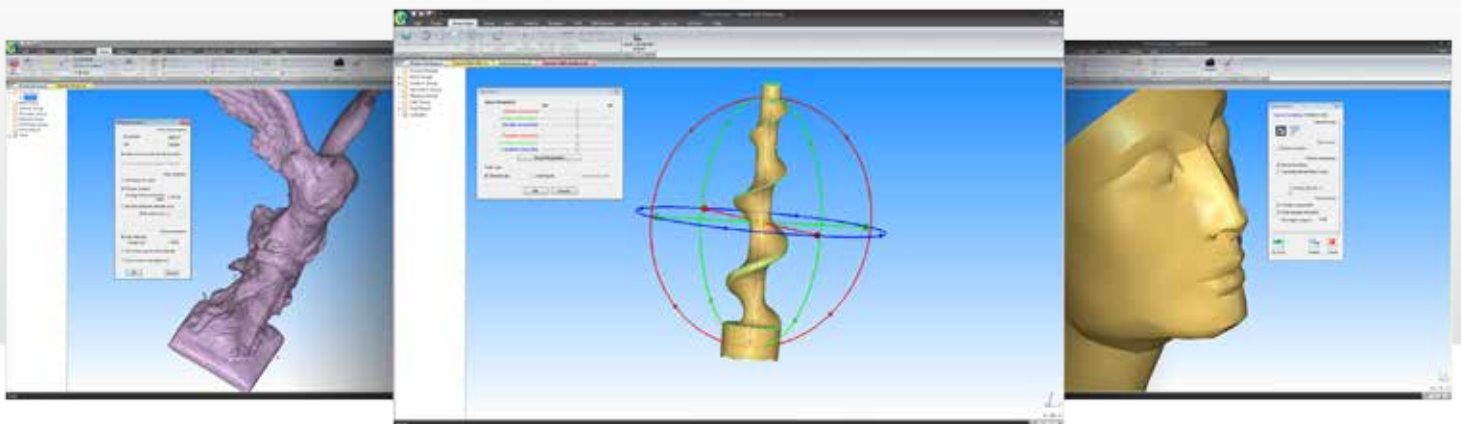

PC-DMIS EMS EXTENSIONS

Software Tools for Special Applications

PC-DMIS EMS offers a range of extensions to the basic PC-DMIS configurations. These can either be stand-alone variations of the core product or add-ons that either control a specialized hardware device such as a rotary table or perform a particular task or group of tasks. Stand-alone variations make it easy to check parts such as blades and gears or simplify overall software operation for specific environments. These include:

PC-DMIS Gear – No Dedicated Gear Measurement Equipment Required

PC-DMIS Gear makes the tough job of gear measurement easy. Features:

- An easy-to-understand, rules driven form to build part programs.
- Measure gears according to a diverse set of international standards including: AGMA 2000-A88, DIN 3962, JIS B 1702 and ISO 1328.
- Align gears, setup and calibrate probes easily using a combination of wizards and predefined routines.
- Generate reports using a full set of industry standard output templates.

PC-DMIS Blade – Software for Blade Measurement and Analysis

PC-DMIS Blade is a turnkey solution for measuring and analyzing blades. PC-DMIS Blade:

- Features a simple to use GUI that lets users identify parts, select sections and initiate scans with minimal effort.
- Accurately simulates traditional, section-based (guillotine) gages at a fraction of the cost.
- Measures characteristics like contour and twist quickly without compromising accuracy.
- Aligns parts quickly using traditional methods like root holding with XYZ offsets and angle rotation to the stacking axis. Also, it supports iterative alignments using CAD surfaces or 6-points rest.

PC-DMIS STI+ Brings Automated Metrology to the Shop Floor

PC-DMIS STI+ lets shop floor personnel check parts without becoming measurement experts by guiding them through part setup and measurement. PC-DMIS STI+:

- Makes the CMM an attractive alternative to functional shop floor gaging by allowing users to run pre-programmed inspections and review reports without any direct interaction with the underlying PC-DMIS software.
- Lets shop floor personnel select inspection programs by picking them from a graphical or alphanumeric list.
- Guides operators through part alignment and fixturing using pictures of the part and fixture.
- Automatically runs the inspection routines and generates graphical reports showing features of interest, including “good part” and “bad part” flags.
- Keeps a history of all parts inspected.
- Turns the CMM into a measurement device that is as simple to use as a go/no go dedicated gage with the flexibility and analytical capabilities of a sophisticated measurement machine.

Options for Productivity

Options allow users to configure PC-DMIS EMS products to meet specific requirements. Supporting special devices, machine configurations or higher level capabilities include:

- Rotary Tables – Control a variety of indexable or infinitely variable rotary tables. Built-in routines simplify table calibration and programming.
- Tool and Tip Changers – Use any of the most popular tool and tip changers with any PC-DMIS package. This module can manage multiple changers on a single machine and provides easy-to-use utilities for changer and probe calibration.
- Supports ISO DMIS input and output allowing the software to both run and export programs in DMIS format and generate results in accordance with the specification.

PC-DMIS EMS

Upgrades and Retrofits Revitalize Any CMM

Bringing New Life to Older Equipment

A PC-DMIS upgrade makes sense whether a measuring machine is used to make a few in-process checks or to inspect the most complex aerospace parts. For a fraction of the cost of a new machine, the latest in measurement technology is available on most older machines.

Hexagon Metrology offers a choice of upgrade packages for all brands of its CMMs, for most other manufacturers' equipment and for a variety of vision systems. Custom configurations are available to suit all applications and budgets. PC-DMIS upgrades fall into two categories: software-only and software/hardware. Both offer distinct advantages.

PC-DMIS software-only retrofits:

- Interface directly to existing hardware without modifying it, significantly improving measurement capability at minimal cost. Typically, retrofits install in less than a day, and machines can still run existing part programs.
- Take full advantage of PC-DMIS's EMS features by sharing programs and data with other EMS components.
- Link CMM and CAD systems, using any of PC-DMIS neutral translators, DCTs or DCIs.
- Provide modern packages that are continually being developed and updated for the manufacturing needs of tomorrow.

PC-DMIS software/hardware upgrades:

- Bring equipment to current standards. Innovative hardware upgrades for manual and DCC machines in all price ranges.
- Enhance the speed and accuracy of their CMM. New hardware and sophisticated volumetric compensation techniques vastly improve machine performance.
- Interface to the newest measurement devices. Hexagon controllers support equipment such as scanning probe heads, non-contact probes, and fixturing systems.
- Improve maintainability and reliability.
- Eliminate the risk and expense associated with maintaining obsolete equipment.

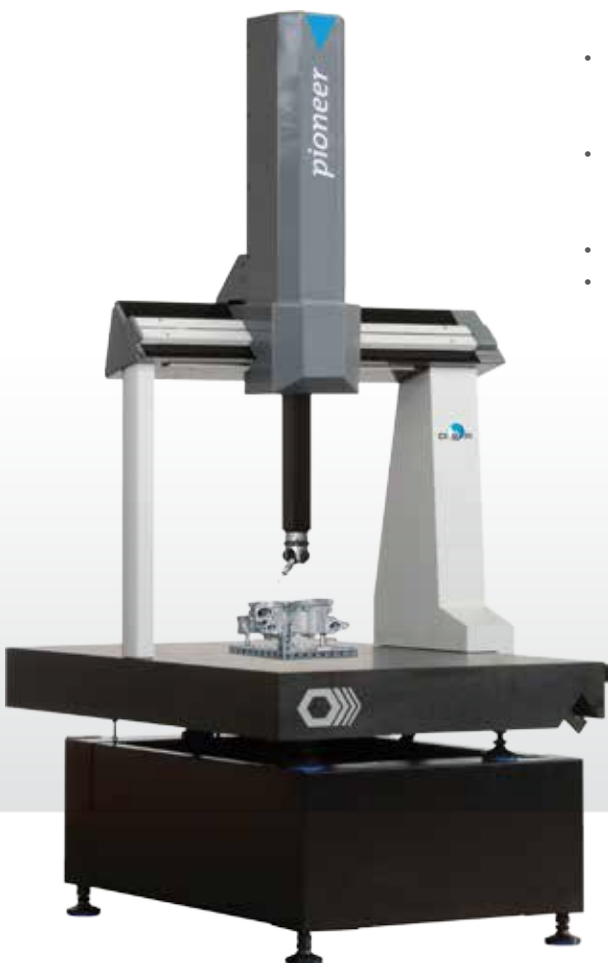

PC-DMIS TOUCH

Touch to Begin

PC-DMIS Touch leverages the simplicity of a tablet interface while harnessing the power of the Windows 8 Professional platform.

With its intuitive touch-screen interface, users quickly inspect single dimensions with no measurement routine programming necessary. Automated routines guide the user through complex measurement tasks with ease and a quick TOUCH saves an inspection plan for additional parts. Interactive on-screen display of measurement features helps the user select the right components when creating dimensions or constructed feature sets. Another TOUCH and the user is able to quickly update nominal and tolerance data and then swipe to the right to view and print an inspection report. Each inspection report is saved independently for future reference.

On DCC CMMs, PC-DMIS Touch uses ClearanceCube technology to control safety moves between features and tool changes. PC-DMIS Touch also includes continuous contact scanning capability for higher accuracy measurement and increased throughput with the ability to run existing PC-DMIS inspection plans.



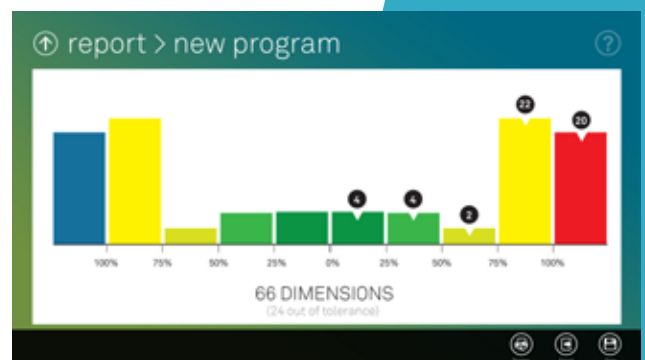
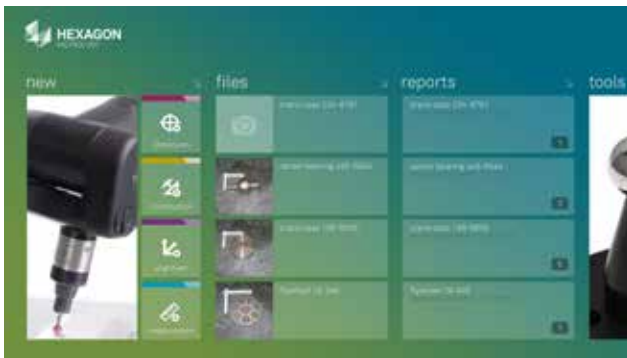

PC-DMIS Touch employs a simple full-screen interface for each measurement task. Since each task is color-coded, the workflow is easy to follow at a glance. Icons at the bottom of the task editor allow quick access to any measurement task at any time.

Measurement tasks like distance between features, feature construction, and GD&T reporting are intuitively guided by the user's input from both physical measurement and selected features. Measured features can be selected from either the large graphical display or directly from a list.

All dimensional reporting is done in real time while the report is viewable and printable any time. Relevant data is captured and calculated automatically as features are measured with the added flexibility to update nominal and tolerance data on the fly.

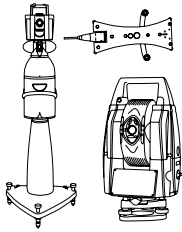

LASER TRACKERS & STATIONS



PORTABLE MEASURING ARMS

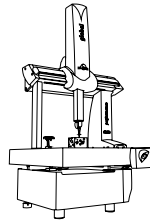

BRIDGE CMMS

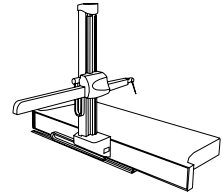

HORIZONTAL ARM CMMS

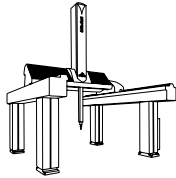

GANTRY CMMS

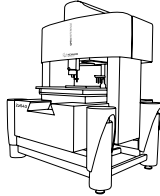

MULTISENSOR & OPTICAL SYSTEMS

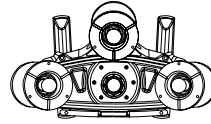

WHITE LIGHT SCANNERS

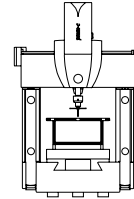

ULTRA HIGH ACCURACY CMMS

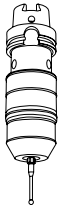

SENSORS

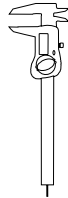

PRECISION MEASURING INSTRUMENTS

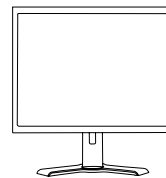

SOFTWARE SOLUTIONS



Hexagon Metrology offers a comprehensive range of products and services for all industrial metrology applications in sectors such as automotive, aerospace, energy and medical. We support our customers with actionable measurement information along the complete life cycle of a product – from development and design to production, assembly and final inspection.

With more than 20 production facilities and 70 Precision Centers for service and demonstrations, and a network of over 100 distribution partners on five continents, we empower our customers to fully control their manufacturing processes, enhancing the quality of products and increasing efficiency in manufacturing plants around the world.

For more information, visit www.hexagonmetrology.com

Hexagon Metrology is part of Hexagon (Nordic exchange: HEXA B). Hexagon is a leading global provider of design, measurement and visualisation technologies that enable customers to design, measure and position objects, and process and present data.

Learn more at www.hexagon.com