

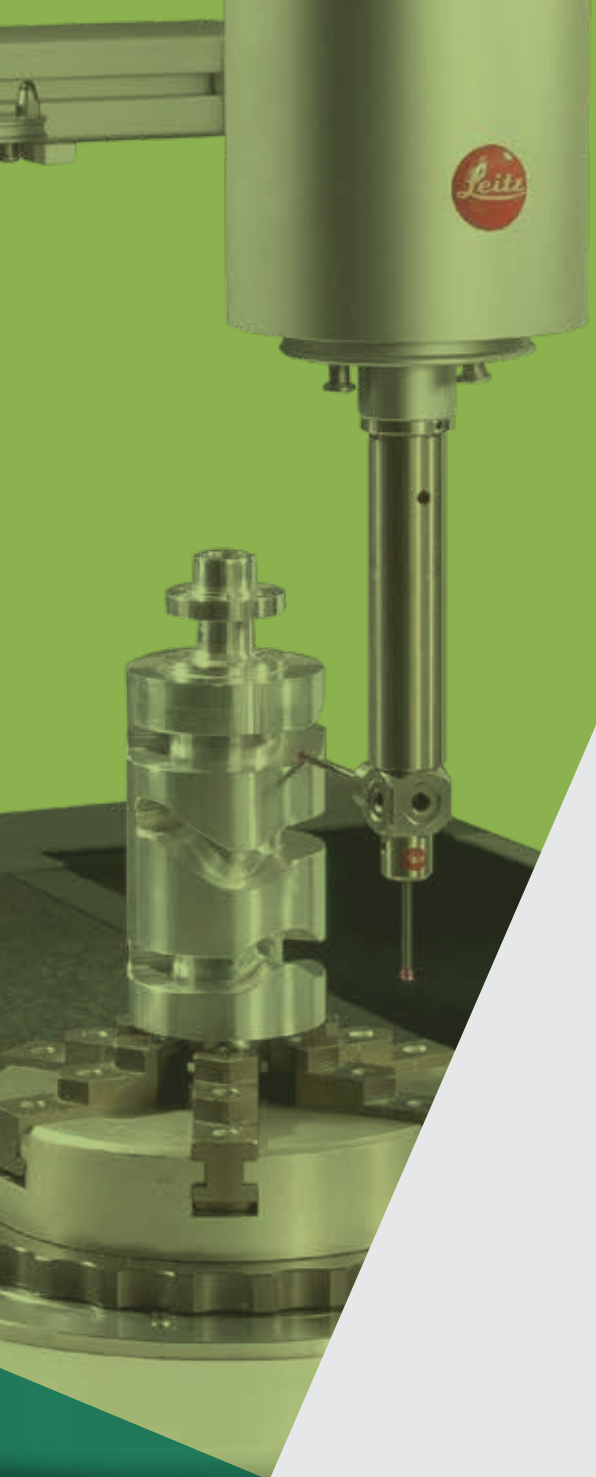

QUINDOS

The PowerTrain Analysis Tool for Coordinate
and Form Measuring Machines







Shaver gear for the precision machining of helical gears

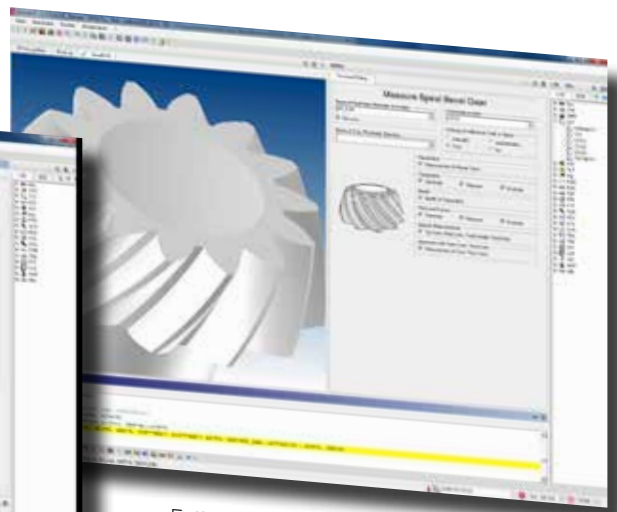

Full access of all stored data



QUINDOS

Continuity as tradition

Continuity plays a decisive role in quality assurance because the credibility of the results must be guaranteed in the long term. Quindos is known in the industry as the software which was upwards-compatible from day one. Continuous development, in manageable increments, minimizes all sources of error. Users appreciate the economic benefits of migrating from one version to the next in one day.

The consequent handling of regular geometries, free-form surfaces and special geometries all on the same machine (CMM or form tester) make for easy access to a wide range of tasks.

As a consequence, Quindos is the reference software for special geometries such as gears, gear tools and control curves.

The database system ensures that even large programs can be processed quickly and the results can be accessed directly, either on line or later.

The programming of features that on other systems have to be carried out interactively is a hallmark of Quindos. The user interface can also be customised to suit the process. User instructions (messages, images, sounds etc.) can be integrated into programs. Programs can also be selected and started using images.

The printing features allow reporting on all printers with Windows drivers. It is now possible to integrate image files into reports as well as formatting the report in Bitmap or JPEG for downloading to the Internet.

The modern help documentation system utilizes images and graphics and cross-referencing to other relevant information. The help documentation can be called up directly from Quindos.

Quindos supports the latest standards, such as I++DME for controlling the CMM/form tester and XML for data exchange.

The fully integrated CAD core allows the 3D representation of all part geometries in combination with moving path information, measured points, calculated elements and coordinate systems. The option CAD Basis can be used to import 3D CAD models by means of which points can be generated, displayed and evaluated. Part parameters can also be used to generate a 3D model of the part (eg. gears).

EFFICIENCY IS THE KEY

When measuring and programming

Fast development cycles are just as important as the production and delivery of parts just-in-time.

For quality control, this means increased efficiency of operation, measurement and programming.

In QUINDOS special selection dialogs help the operator to access programs and make simple decisions.

Only the necessary features are measured. Parallel processing of time-intensive evaluations means that modern multi-core computers can be fully utilized.

It is always important that the programmer can modify existing programs quickly. QUINDOS, combined with its programming style and copy/paste functions, has the necessary prerequisites. Loops and conditional jumps accelerate the creation and execution of programs.

Utilising the information contained in the CAD model, the experienced user can create executable programs within a very short time.



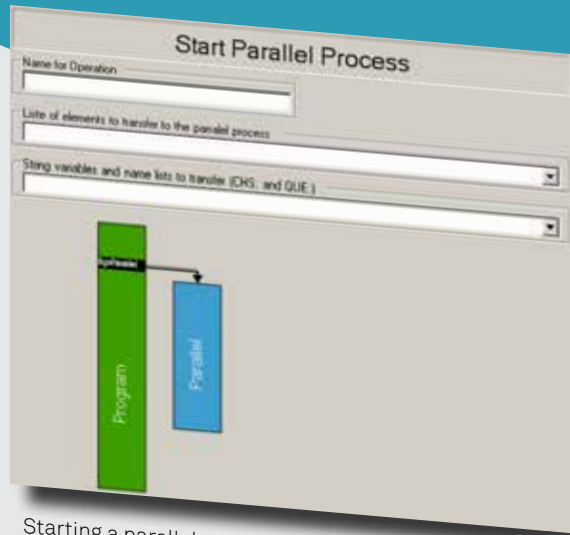

Starting a parallel process for a multi-processor system

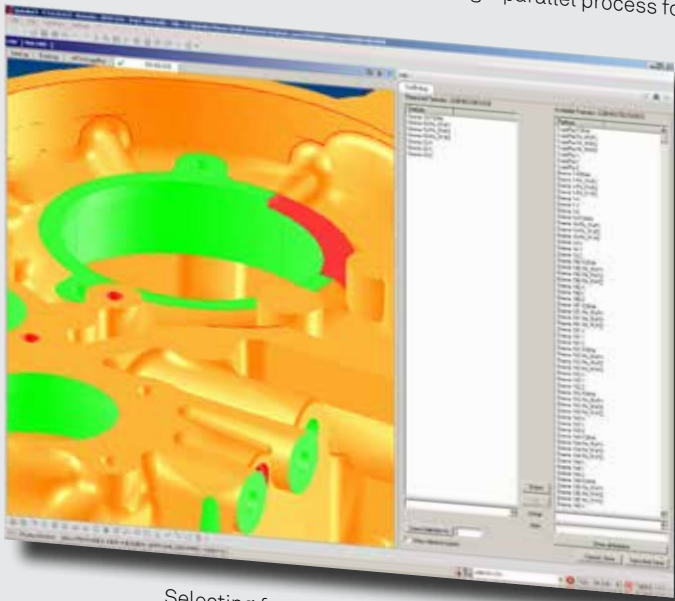

Selecting features for measurement



GRAPHICAL INTERFACE

New, but still familiar

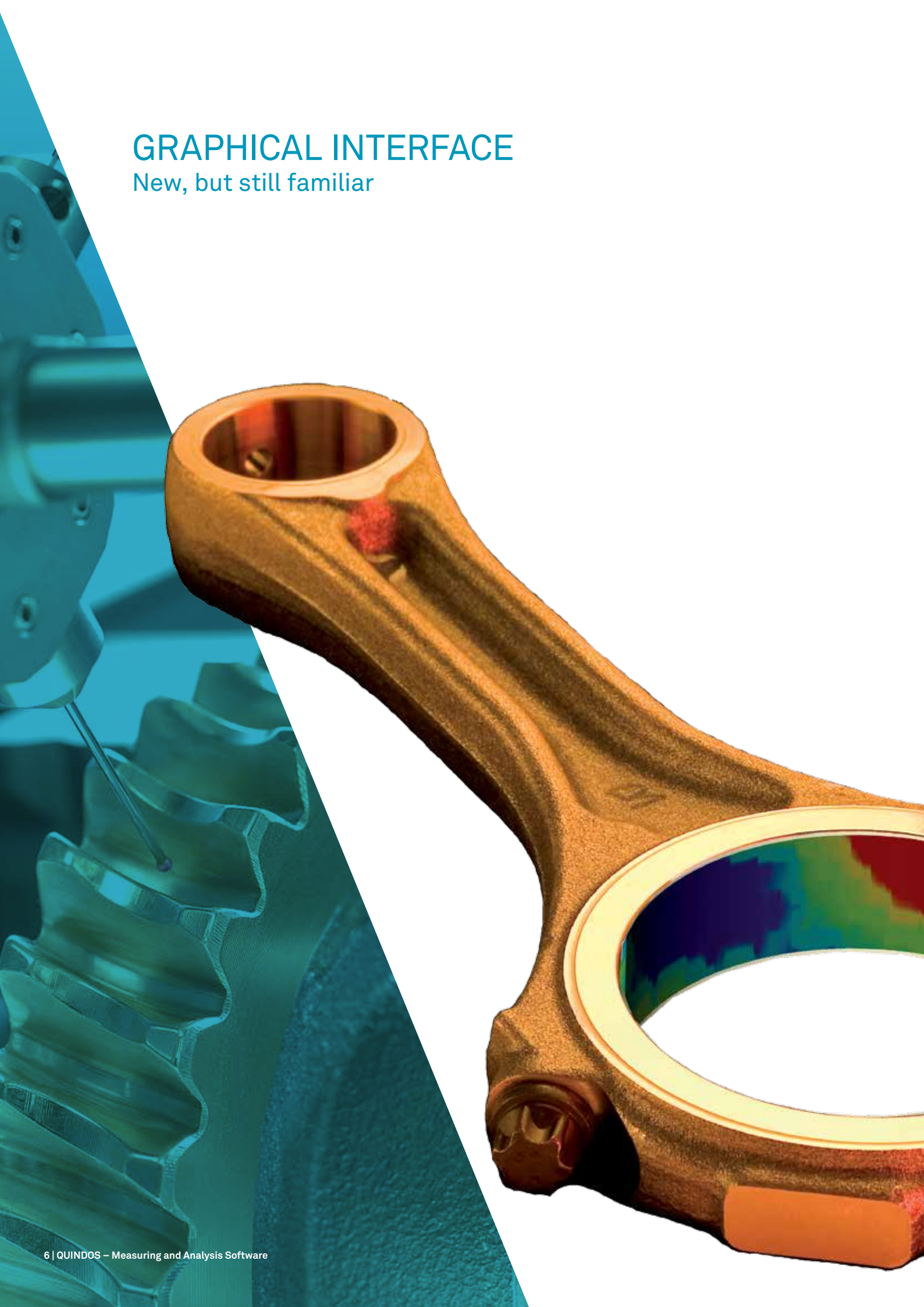

The mass of information makes a good user interface compulsory. The partitioning as well as the size of the QUINDOS graphical interface is freely selectable by the user. Customised layouts can be saved as snapshots for use at a later date.

The program text appears in a modern, multi-colour text editor with spell checker and drag-and-drop functionality. Automatic completion helps to find the correct command syntax, while automatic insert helps to complete a line of code.

Individual commands and parameters can be modified using customized dialogue pages. The dialogues are dynamic and are modified in real time by the user inputs.

Depending on the current command, a selection of icons appropriate to the next command will be presented.

The database browser can be used to access all object types (Elements, coordinate systems, procedures, tools etc.) for viewing or editing. Nothing is hidden from the user.

Error handling has always been a strength of QUINDOS. This has now been improved using error lists and error helps for more transparency.

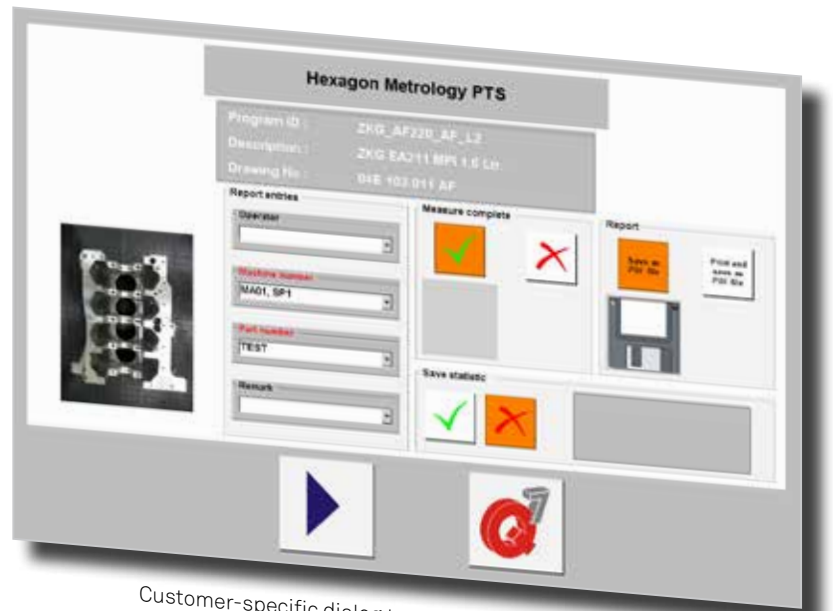

Customer-specific dialog to select measuring programs

When used in connection with a machine, every point taken is used to recalculate the element and refresh the deviations visual. If a CAD model is not available, the element surface is created using the measured points.

For advanced programming, the experienced user can use the Dialog Editor to create customized input dialogs, utilizing photos, drawings and graphics (a special SVG Editor is integrated into QUINDOS for this purpose). These tools can be used to create a user-specific graphical interface to make the operator's job easier.

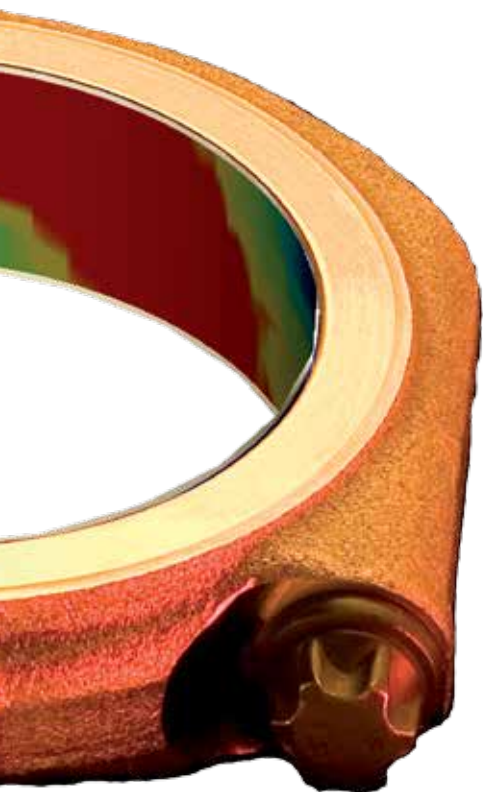

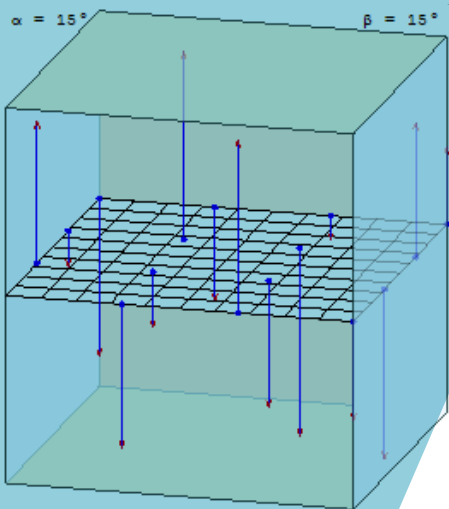
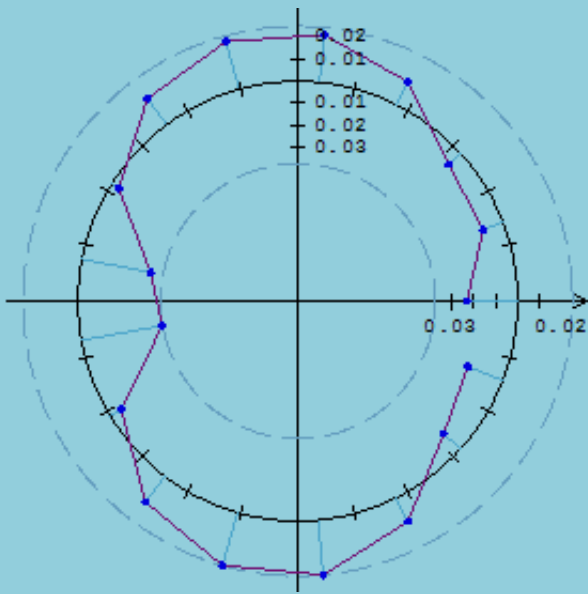

PROCESS PLANNING USING CAD

Intelligent methodology for more profitability

The most noticeable new feature of QUINDOS is the CAD core. The part geometry can be represented and manipulated (zoom, rotate, pan) in 3D. This functionality is available not only for CAD models but also in the more traditional teach-in mode. Point patterns can be generated interactively and measured points can be represented with their corresponding deviations and calculated element.

The QUINDOS basic program can be used to represent nominal and actual points on the calculated surface. Even without a CAD model, all of the measured elements can be represented spatially.

The CAD-Basic option makes it possible to generate moving path information for geometrical elements. The SafetyBox takes care of collision-free travel between elements (with and without CAD model).

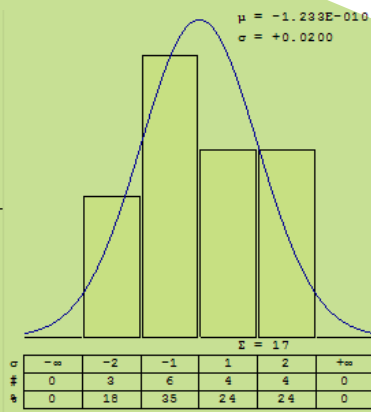
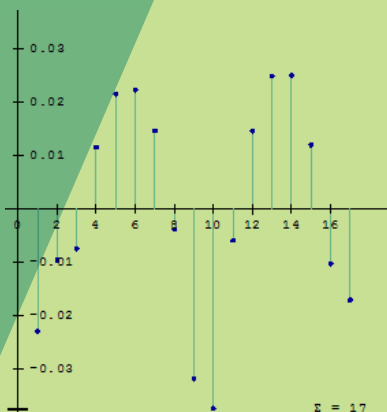

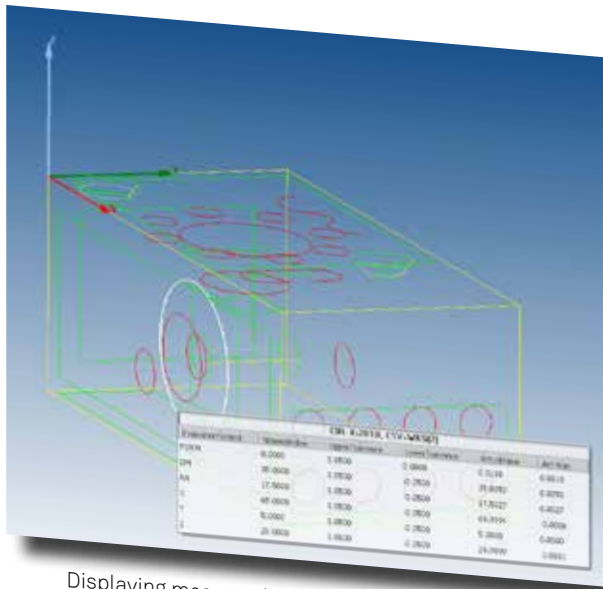

Displaying measured features without CAD-model

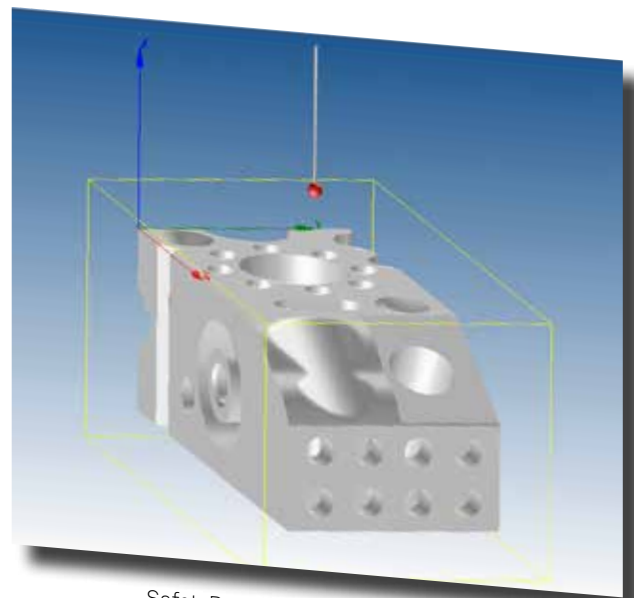

SafetyBox for collision-free probing

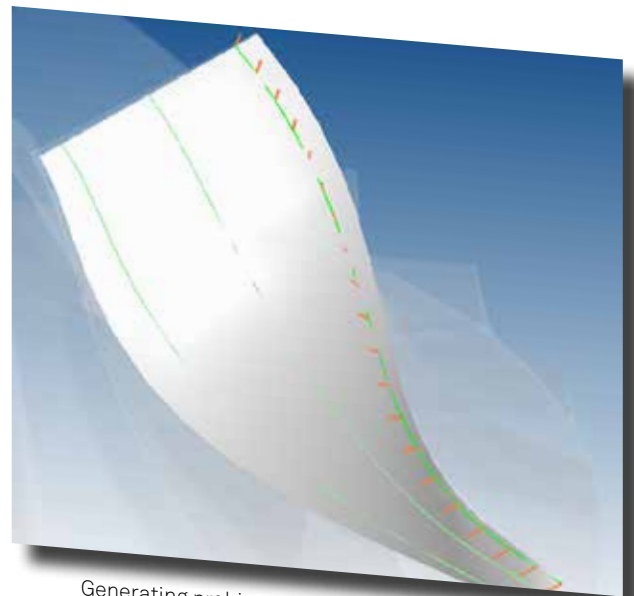

Generating probing points on functional surfaces

Every geometric element is assigned to a group of surfaces which in turn can be used to make selections for further analysis (e.g. connections). IGES, STEP, Catia V5, Unigraphics NX and Pro-E model formats are currently supported. A wizard analyses the model, removing invisible and redundant surfaces, unifying the surface directions and identifying both simple and complex features (feature recognition).

The CAD-Surfaces option can be used to generate points with the correct normals on curves and surfaces using grids or section lines (utilizing planes, cylinders, edge offsets etc.).

Measured points can also be represented at any time, independent of the program currently running. Every coordinate system in the program can be selected and displayed.

Inspection planning, utilising the I++ Simulator, is an ideal way to check the machine movement and avoid collisions.

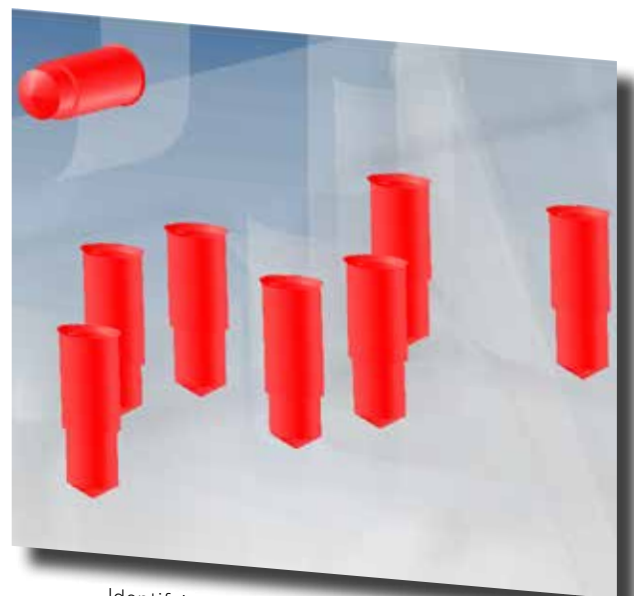

Identifying simple and complex geometries

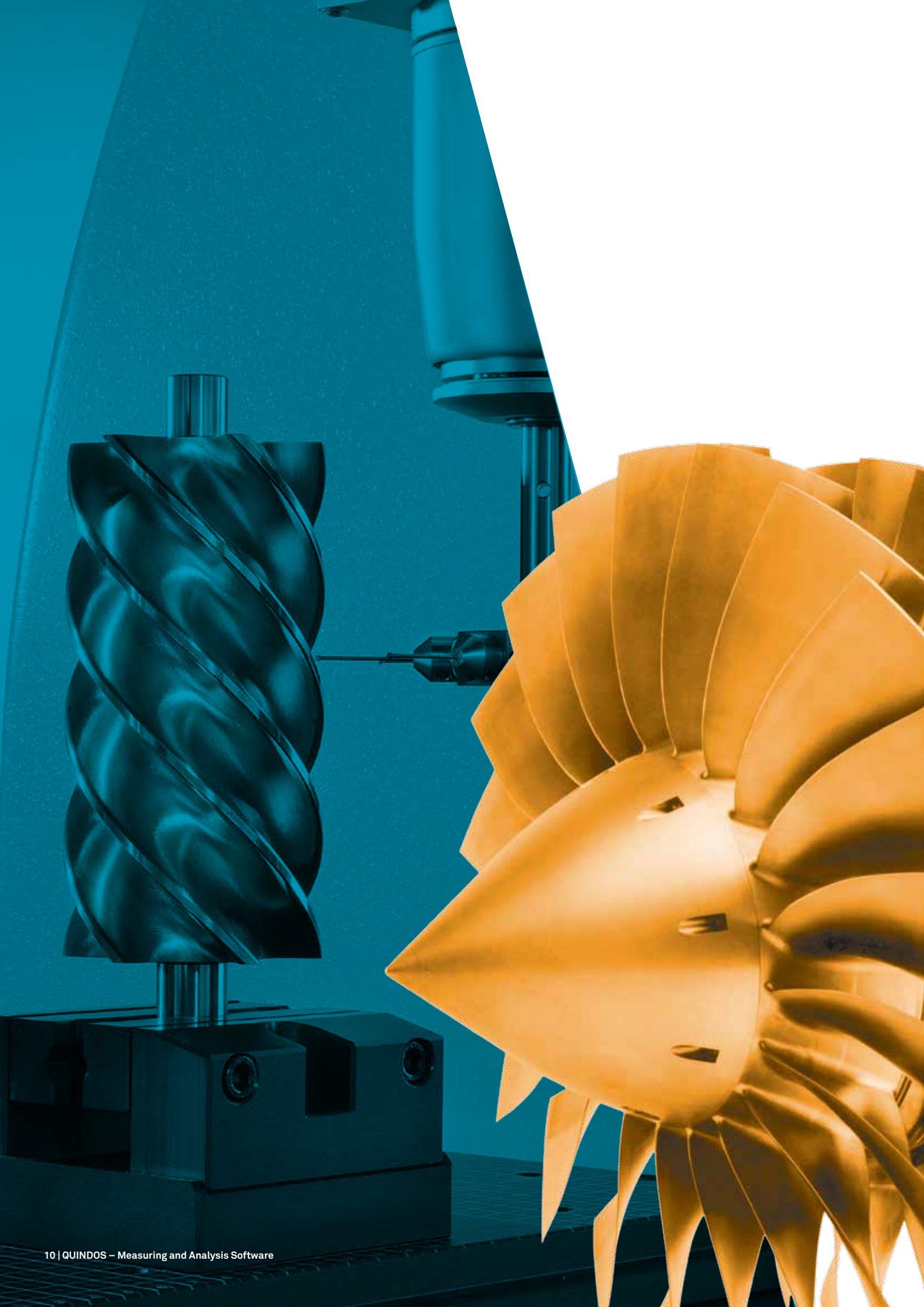

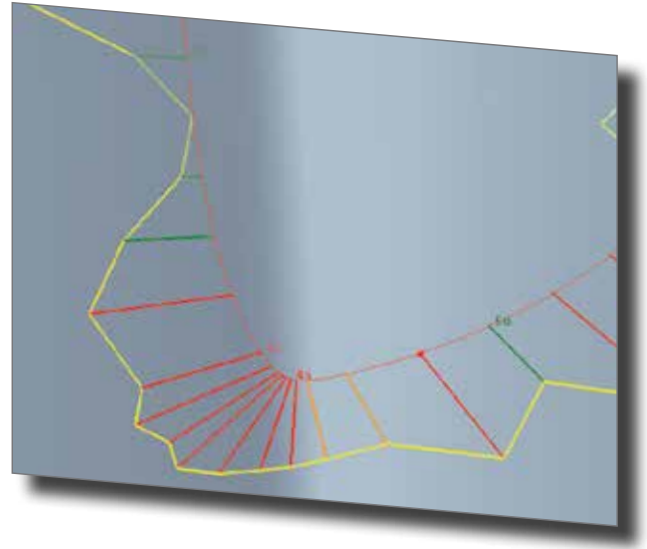
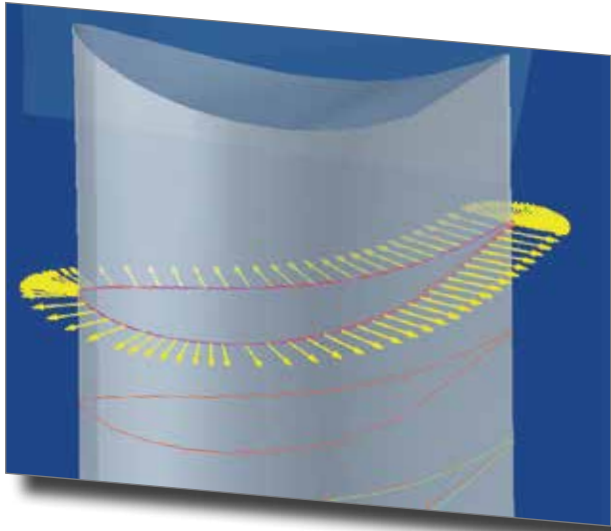

MEASUREMENT ANALYSIS

The right tools for every task

From day one, QUINDOS was developed for use on precision measuring machines with scanning functionalities. The mathematical algorithms are implemented accordingly. There are various types of calculation methods which can be applied to turn measured points into elements (e.g. inscribed, exscribed, least squares etc.). Furthermore, individual element parameters can be fixed and the resulting element calculated accordingly.

As well as the standard geometrical elements, ellipse, ellipsoid, parabola and paraboloid algorithms are also implemented.

For form testing with either dedicated form testers or scanning CMMs, points can be filtered using either high or low pass filters or Fourier analysis. All of the information pertaining to the feature is stored in a transparent database system for further analysis.

Logical decisions can be made which can control the further analysis of the measuring results automatically. This also applies to freely selectable text and file names.

Integrated mathematical functions can be used to manipulate data according to company-specific requirements.

Statistical evaluations are also possible. QUINDOS can be used to compare current data with previous measurements or the measured data can be exported for analysis in other applications.

QUINDOS options can be used to create enhanced evaluations, such as curves, surfaces or special part families.

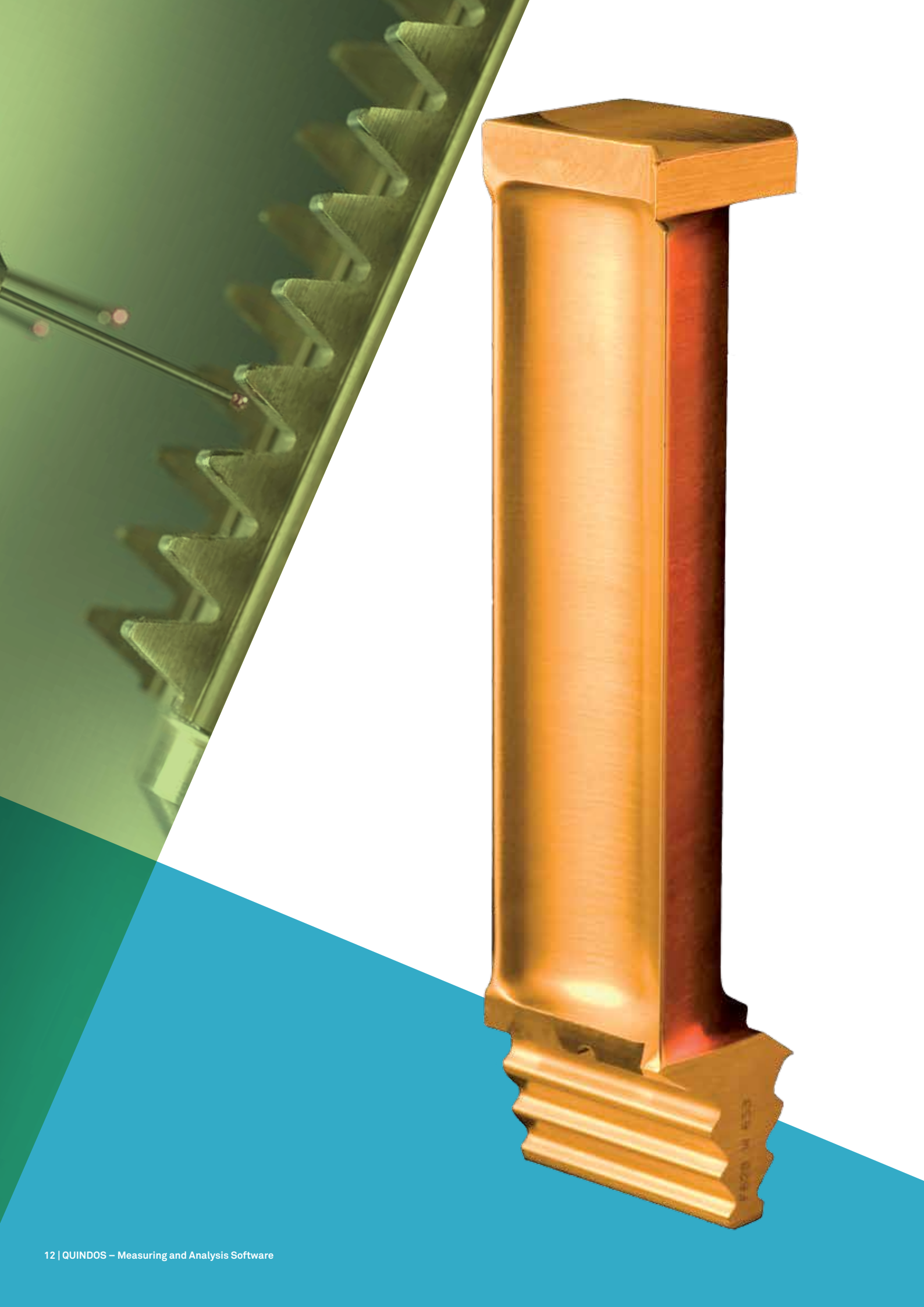

FORMATTING THE RESULTS

To suit the recipient

The recording and processing of the measurement data as well as the evaluation of the individual features can be represented spatially. The 3D interactive analysis and evaluation of the measured points can be used to appraise geometrical surfaces, free-form surfaces and curves with or without the associated CAD model.

Presentation of the results

The format and archiving of results do not always live up to expectations. Both the PageViewer and the ReportViewer create a paged file in document format (.GIF, .JPG, .BMP, .PDF) which can be printed on any windows printer.

The file name can be defined from within the program, depending on the recipient.

PageDesigner

The PageDesigner can be used to create custom report formats, e.g. for different component types.

Multi-page layouts, utilising graphics, texts and tables, can be integrated in a single document which can be viewed on line.

The report format is independent of the report contents. Different formats can be used to format the report contents for different recipients.

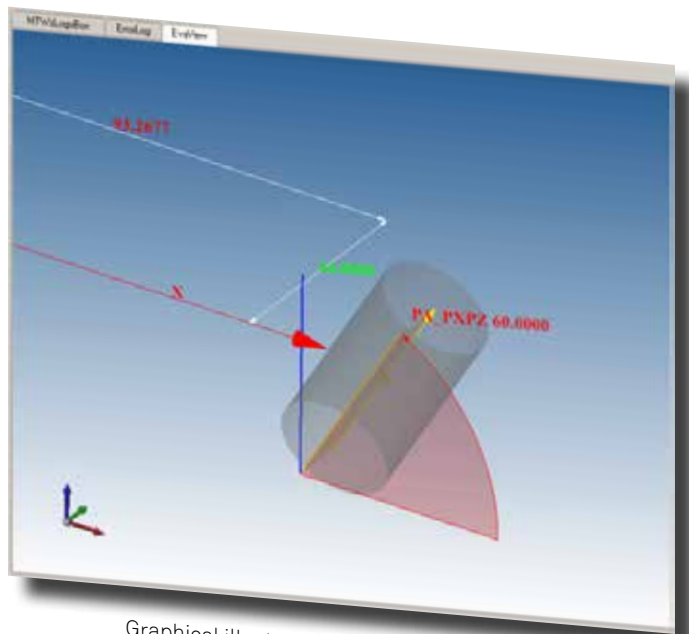

Graphical illustration of evaluated features

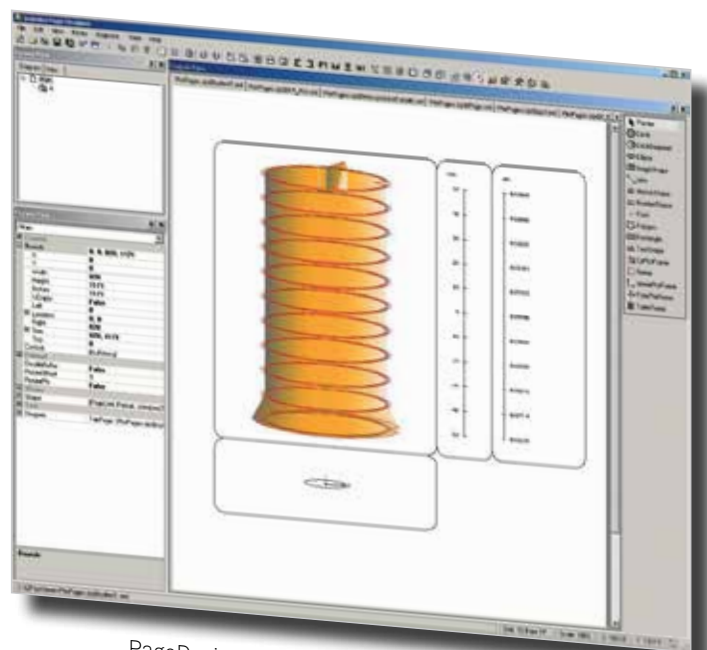

PageDesigner: customized graphical reporting

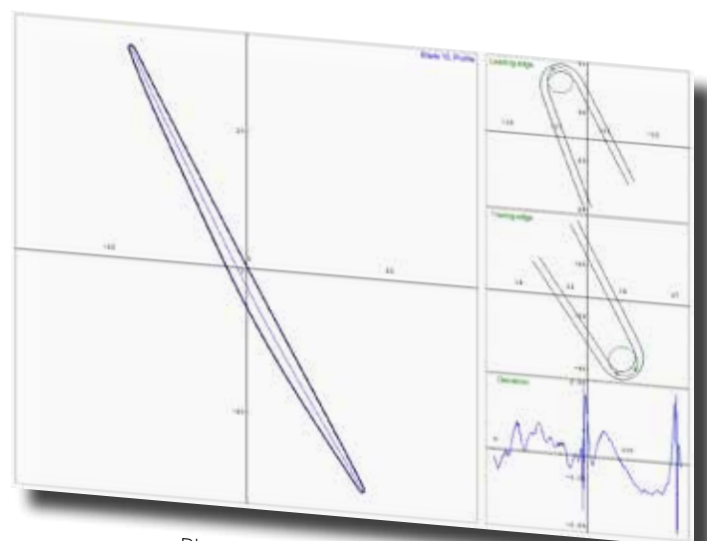

Blade evaluations (typical example)

MODULAR UPGRADING

Unbeatable for special geometries

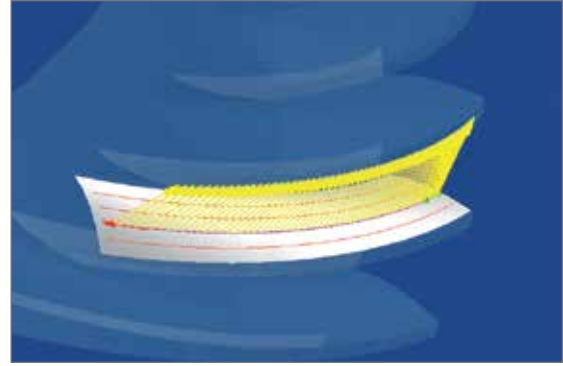

Gears

Gears (cylindrical, straight/helical, internal/external, serration)

Unknown Gears („Reverse Engineering“)

Gear Gages

Straight Bevel Gears

Spiral Bevel Gears

Sprockets

Serration Gears

Customer-specific Gear Evaluations

Curvic Couplings

Gear Cutting Tools

Hob Cutter

Broaches

Shaper Cutters

Shaving Gear

Form Cutters (Customer-specific)

Worms

Worm Wheels for Cylindrical Worms

Cylindrical Worms

Globoid Worms

Miscellaneous

Screw Compressors

Camshafts

Step Gears

Impellers

Aspheric Surfaces

Threads (ISO and API)

Blades

Complementary Cams

Valve Seats and Guides

Ovality of Pistons

Constant Velocity Joint

No other software is stronger in the field of special geometries as QUINDOS. There are several options available, all dedicated to the measurement of gears (straight gears, bevel gears, serrated gears, unknown gears, gear standards etc.), gear cutters (hobs, broaches etc.) and worm gears (worms, cylindrical worms etc.). Coordinate measuring machines exceed the requirements of a conventional gear measuring centre. Palettised gears and components which combine gears with other geometries can also be accommodated.

QUINDOS is also at the leading edge when it comes to other special geometries.

The part parameters and the inspection plan are used to generate the moving path information and measure the part fully automatically. Parts can be measured with or without a rotary table.

The measurement and evaluation of all special geometries conforms to the appropriate national and international standards.



Typical gears and gear cutters

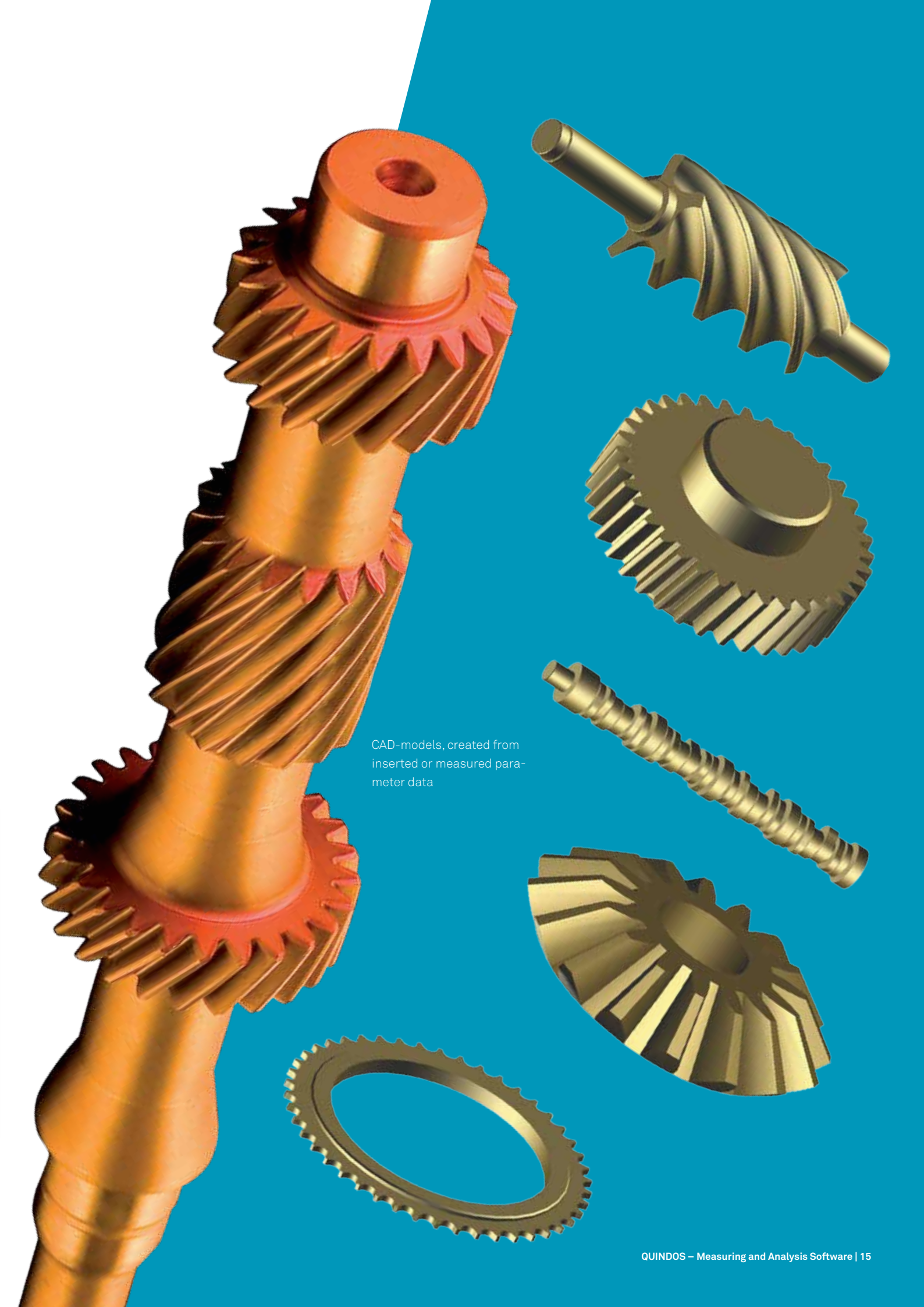

CAD-models, created from
inserted or measured para-
meter data

MODULAR UPGRADING

For every task the right solution

QUINDOS also has a comprehensive array of specialised applications, covering a wide spectrum of parts.

CAD Options

- CAD Basis
- CAD Surfaces
- CAD Inspection Planning Tools
- CAD Reverse Engineering Tools
- CAD Import Interfaces for CATIA V4/V5/V6, Unigraphics, Pro/Engineer

Miscellaneous QUINDOS Options

- Curves
- Wear Measurement
- 2D Gauging
- Polygon
- Digitising of Surfaces
- 3D Gauging of Points and Elements (measured points in multiple geometric elements)
- Measuring Part Pallets
- Feature-based Inspection
- Digital Input/Output Interface
- Automatic Gauge Inspection
- Automatic Calculation of Tolerances for Gauge Inspection
- Connecting Rods
- Relational Database Interface (SQL)
- Centering of Balls
- Compare Part Programs
- FUBIT Interface

Statistic Packages

- Statistics (interactive real-time)
- Statistic Feature Overview
- STATviewer

CMM Check and Acceptance Programs

- CMMCheck
- CMM Test with Ball Plate
- ISO 10360 (-2, -3, -4, -5) with Step Gauges and Gauge Blocks
- Offline CMM Probing Error Simulation

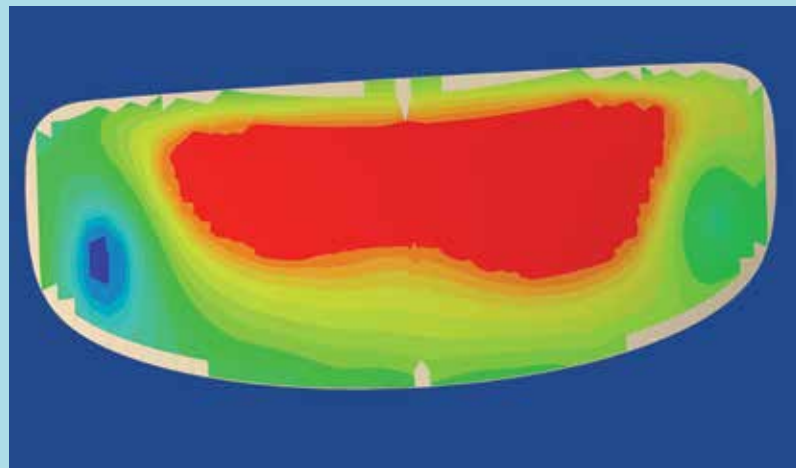

Deviation representation on the CAD model

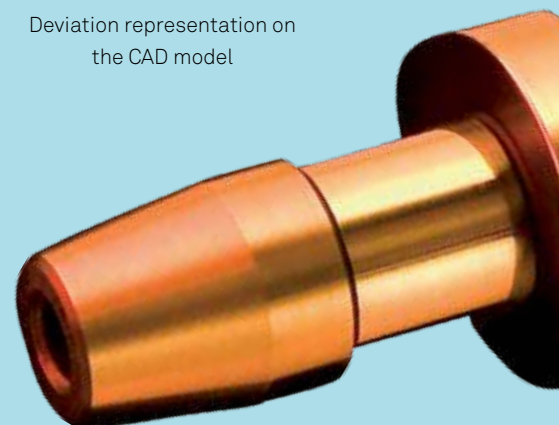

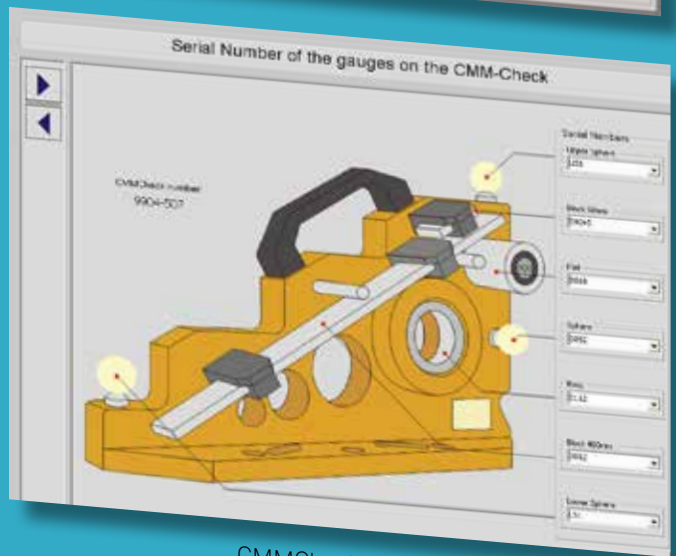
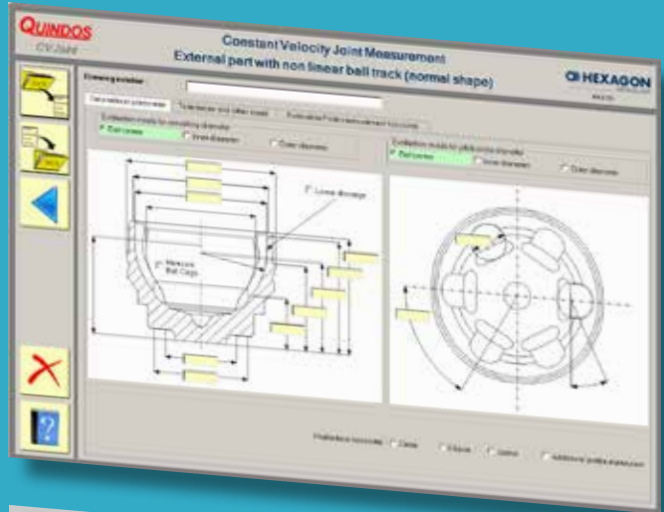

CMMCheck dialog

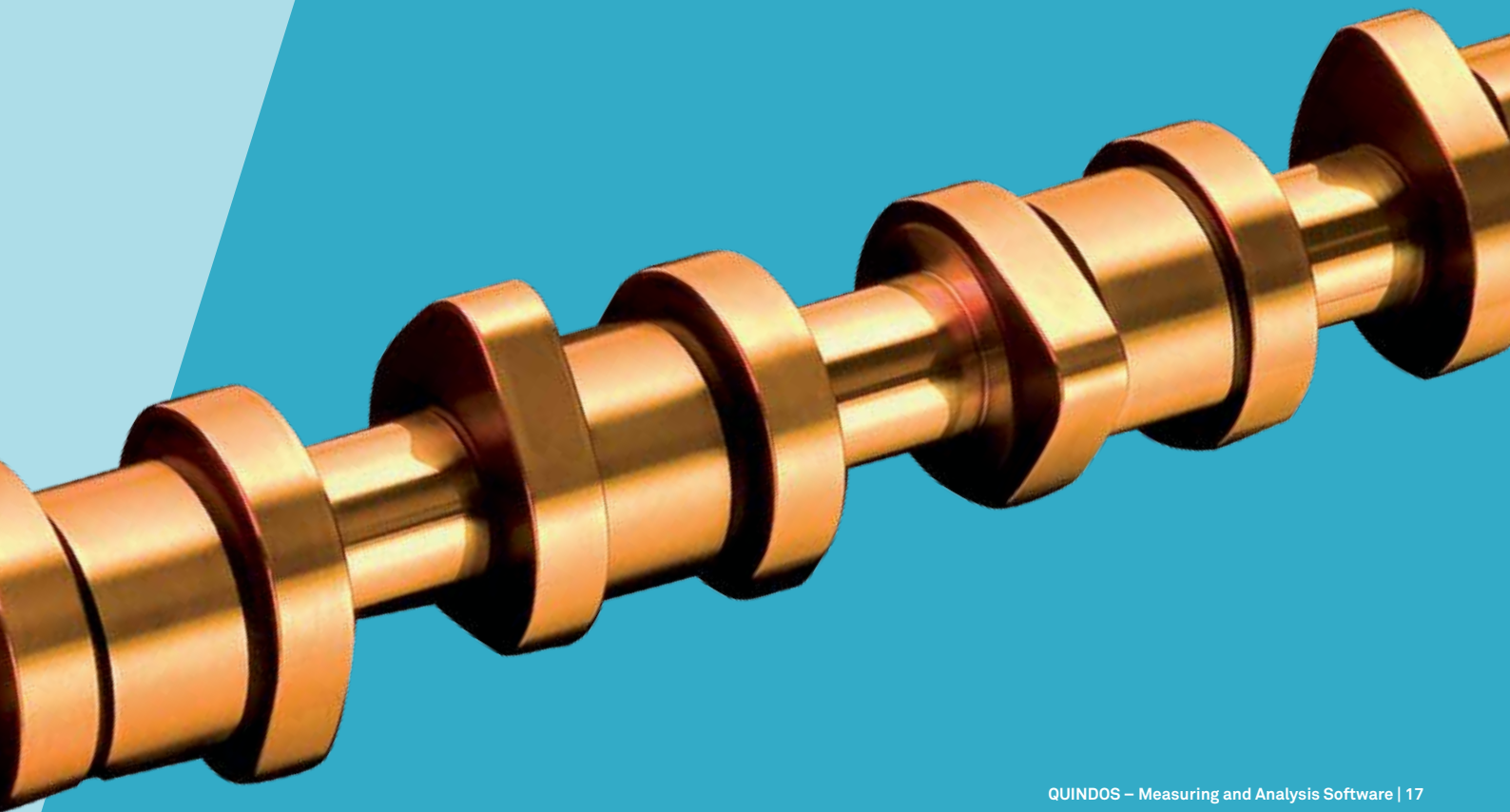

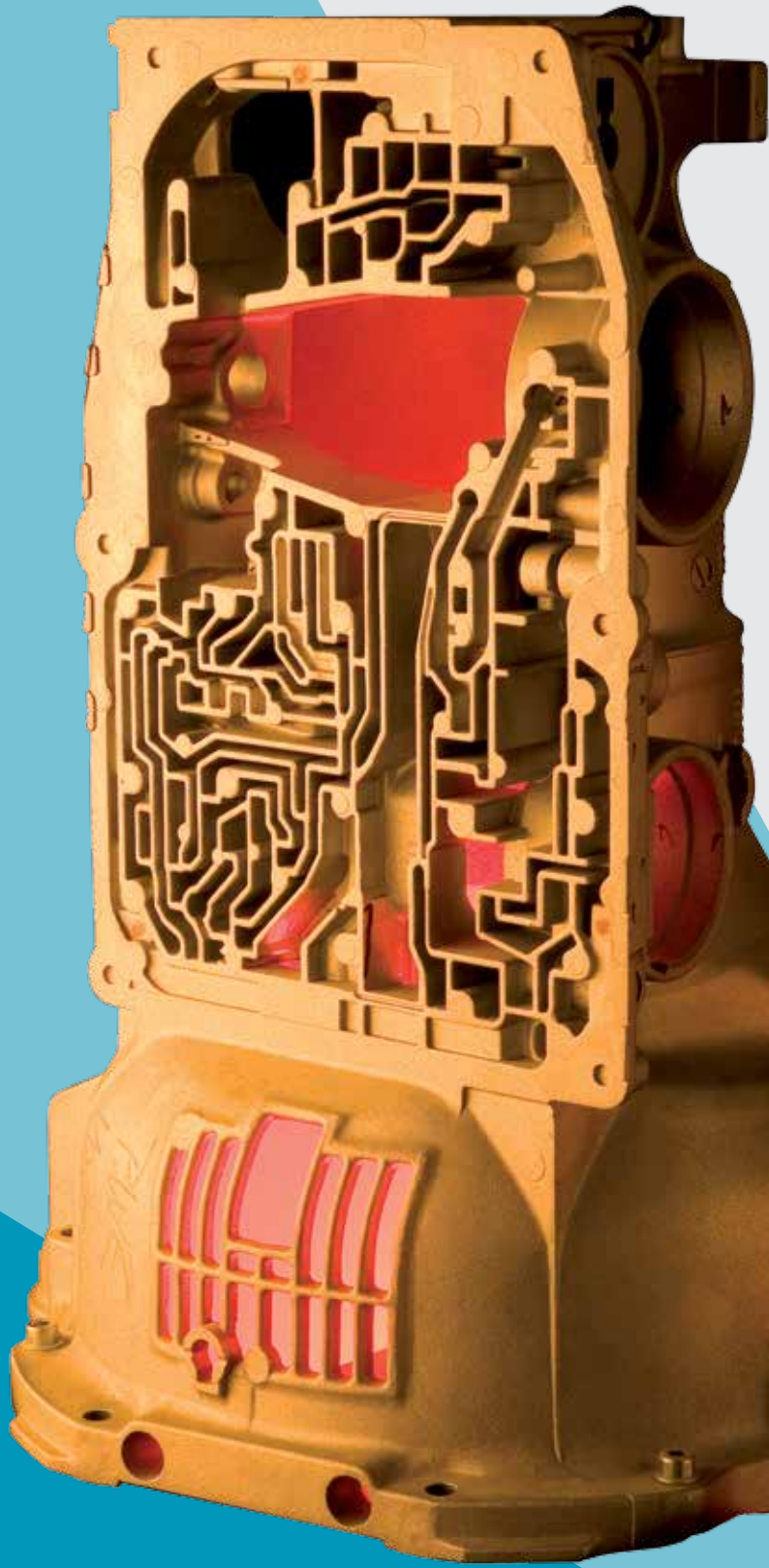
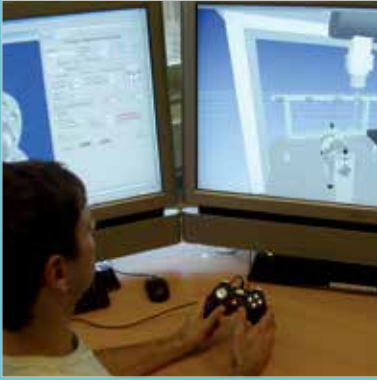

YOUR CHOICE OF MACHINE

With I++DME into the future

QUINDOS has its sights set on the future: I++DME is an integral part of every installation. Every CMM which supports this interface can be used with QUINDOS. As a result, machines from different manufacturers can be used with one and the same software and produce the same comparable results.

Users can now select the most appropriate software for the measurement in question. The probing method most suited to the application and machine type is always selected.

Because this interface is only available on new machines, QUINDOS drivers are available for existing CMMs and form testers from Mahr, Hommel and Adcole.

QUINDOS also has routines for calibrating all of the various probing systems and probe changers.

Even „virtual measuring devices“ can be controlled through this interface like the I++Simulator or the 3DReshaper from Hexagon Metrology.

An automobile industry working group has been working on standardising interfaces in the CMM industry since 1999.

The most wide-reaching result of its work is the I++DME (Dimensional Measuring Equipment) interface, a universal standard for CMMs, form testers and other length measuring instruments. All of the leading machine manufacturers have implemented the I++DME interface.

Simplifying the data exchange between CAD systems and measurement strategies is one of the next goals of the working group.

Hexagon Metrology PTS has worked closely with it since its inception. The implementation of their standards in QUINDOS is secured.



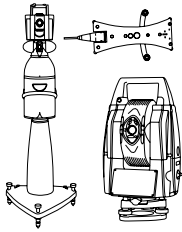

LASER TRACKERS & STATIONS



PORTABLE MEASURING ARMS

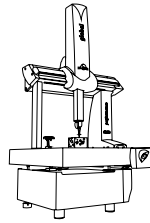

BRIDGE CMMs

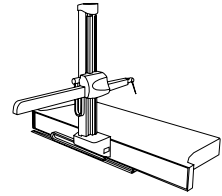

HORIZONTAL ARM CMMs

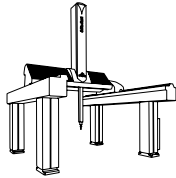

GANTRY CMMs

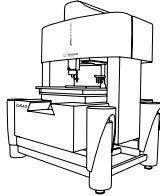

MULTISENSOR & OPTICAL SYSTEMS

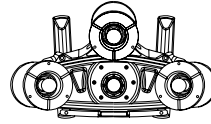

WHITE LIGHT SCANNERS

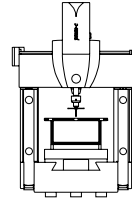

ULTRA HIGH ACCURACY CMMs

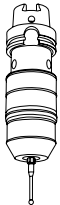

SENSORS

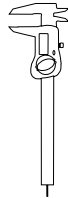

PRECISION MEASURING INSTRUMENTS

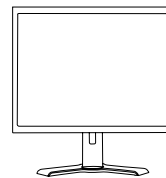

SOFTWARE SOLUTIONS



Hexagon Metrology offers a comprehensive range of products and services for all industrial metrology applications in sectors such as automotive, aerospace, energy and medical. We support our customers with actionable measurement information along the complete life cycle of a product – from development and design to production, assembly and final inspection.

With more than 20 production facilities and 70 Precision Centers for service and demonstrations, and a network of over 100 distribution partners on five continents, we empower our customers to fully control their manufacturing processes, enhancing the quality of products and increasing efficiency in manufacturing plants around the world.

For more information, visit www.hexagonmetrology.com.

Hexagon Metrology is part of Hexagon (Nordic exchange: HEXA B). Hexagon is a leading global provider of design, measurement and visualisation technologies that enable customers to design, measure and position objects, and process and present data.

Learn more at www.hexagon.com.

© 2013 Hexagon Metrology. Part of Hexagon

Due to continuing product development, Hexagon Metrology reserves the right to change product specifications without prior notice.

Printed Germany. November 2013