

HORIZON + Granite

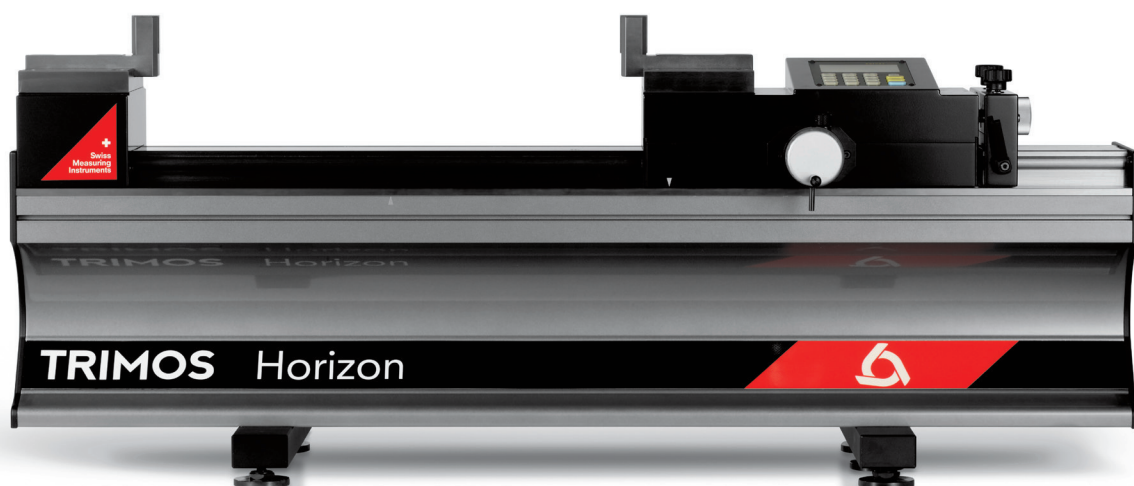

HORIZON + Granite

INTRODUCTION

The «Horizon» instruments respond to the current requirements for quality inspection in manufacturing areas. They allow a quick, precise checking and setting.

The instruments are perfect for setting all kinds of comparative measuring equipment and for checking length, internal and external diameters, thread gauges etc.

The new innovative concept with incorporated measuring system and display unit ensures excellent results by easy manipulation and is the answer to various demands in the field of production. Simplicity of use is an additional valuable advantage.

The instrument range comprises several models, from 500 mm up to 2000 mm (Granite 3000 - 8000 mm). A wide selection of easy interchangeable accessories completes the application possibilities.

IDEAL FOR USE IN THE WORKSHOP AREA

VERY SIMPLE MANIPULATION

PRECISE CHECKING AND SETTING MADE EASY

SELF-CONTAINED OPERATION OF APPROX. 100 HOURS

WIDE SELECTION OF ACCESSORIES

DESCRIPTION

HORIZON

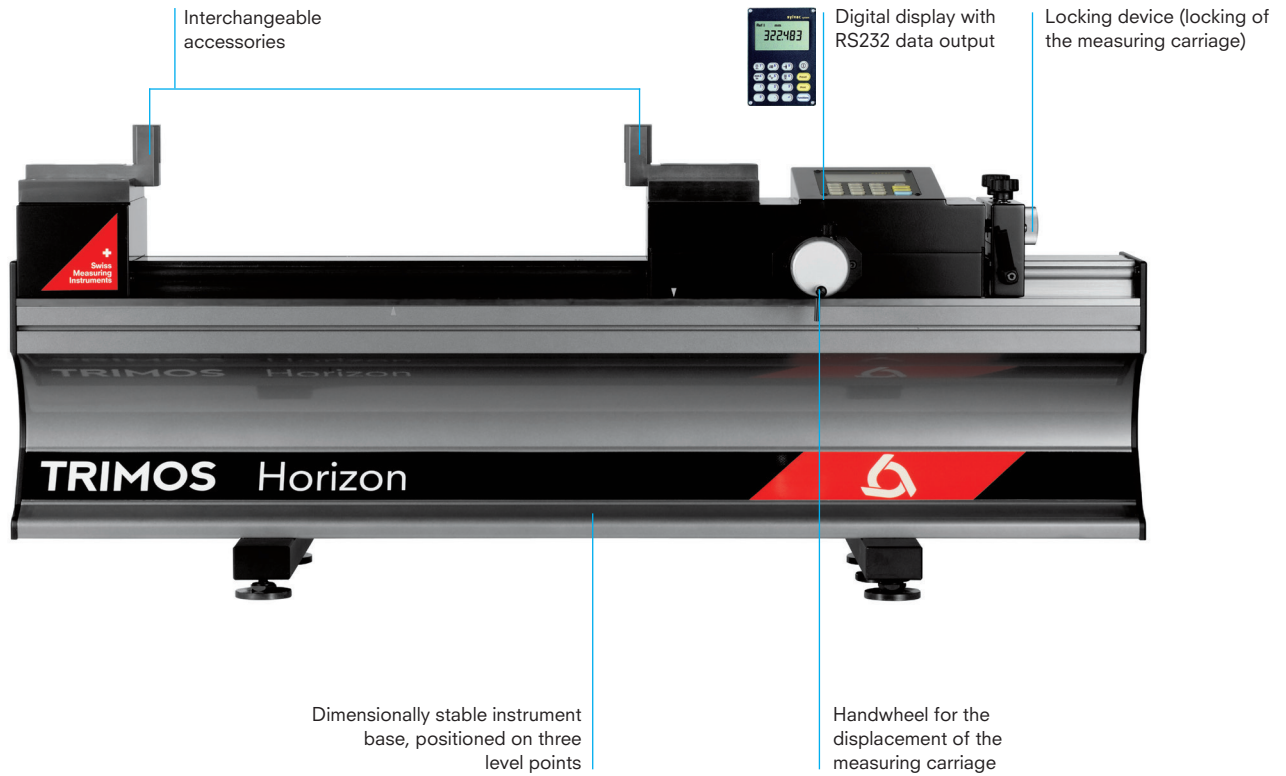

HORIZON GRANITE



HORIZON + Granite

DISPLAY / SOFTWARE

HORIZON

- SELECTION OF VALUE: NORMAL / MIN / MAX

- ZERO SETTING OF THE DISPLAY AND PRESET INPUT

- RS232 DATA OUTPUT

- TWO REFERENCES

- SELECTION OF THE RESOLUTION 0.01 MM - 0.001 MM

- SELECTION OF MEASURING UNIT MM / INCH (DIRECT CONVERSION)



sylvac system

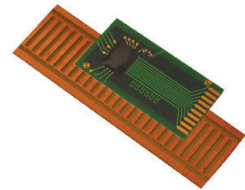

HORIZON GRANITE

Heidenhain ND287 or ND1100

- LINEAR MEASUREMENT DISPLAY AND MIN. / MAX. VALUE HOLD

- DIGITAL DISPLAY

- ZERO SETTING OF THE DISPLAY AND PRESET INPUT

- PARAMETER SETTINGS

- INITIALIZATION OF THE DISPLAY USING EXTERNAL FUNCTION

- RS232 DATA OUTPUT



Heidenhain ND287



Heidenhain ND1100



PC with software WinDHI

- GRAPHIC HELP FOR MEASURING FUNCTIONS

- SELECTION OF THE MEASURING UNIT MM / INCH

- DIRECT DISPLAY OF ALL LENGTH MEASURING VALUES AND MIN. / MAX. VALUE HOLD

- INPUT OF 9 PRESET VALUES

- INVERSION OF MEASURING DIRECTION SIGN (+/-)

- DATA TRANSFER USING A FOOT PEDAL



TECHNICAL SPECIFICATIONS

Horizon		H501	H1001	H1501	H2001
Measuring range	mm (in)	520 (20)	1020 (40)	1520 (60)	2020 (80)
Max. permissible errors ¹⁾	µm	2.5 + L/300			
Repeatability (2s) ¹⁾	µm	1			
Resolutions	mm (in)	0.01/0.001 (.0001 / .00005)			
Max. displacement speed	mm / s	1500			
Measuring force	N	3			
Autonomy	h	100			
Interface		RS232			
Operational temperature	°C	+10 ÷ +40			
Temperature of storage	°C	-10 ÷ +40			
Weight	Kg	94	126	158	190

¹⁾ Values valid at temperature of 20 ± 0.2 °C and relative humidity of 50 ± 5%.

Horizon Granite		HG3000	HG4000	HG5000	HG6000	HG8000
Measuring range	mm (in)	3000 (118)	4000 (157)	5000 (196)	6000 (236)	8000 (315)
Max. permissible errors ¹⁾	µm	0.7 + L/750				
Repeatability (2s) ¹⁾	µm	0.5				
Resolutions	mm (in)	0.01 / 0.001 / 0.0001 (.001 / .0001 / .00001)				
Max. displacement speed	mm / s	2000				
Measuring force	N	3				
Interfaces		RS232/USB				
Operational temperature	°C	+10 ÷ +40				
Temperature of storage	°C	-10 ÷ +40				
Relative humidity	%	20 ÷ 80				
Weight	Kg	1060	1980	3200	3700	4600

¹⁾ Values valid at temperature of 20 ± 0.2 °C and relative humidity of 50 ± 5%.

HORIZON + Granite

SCHEMA

HORIZON

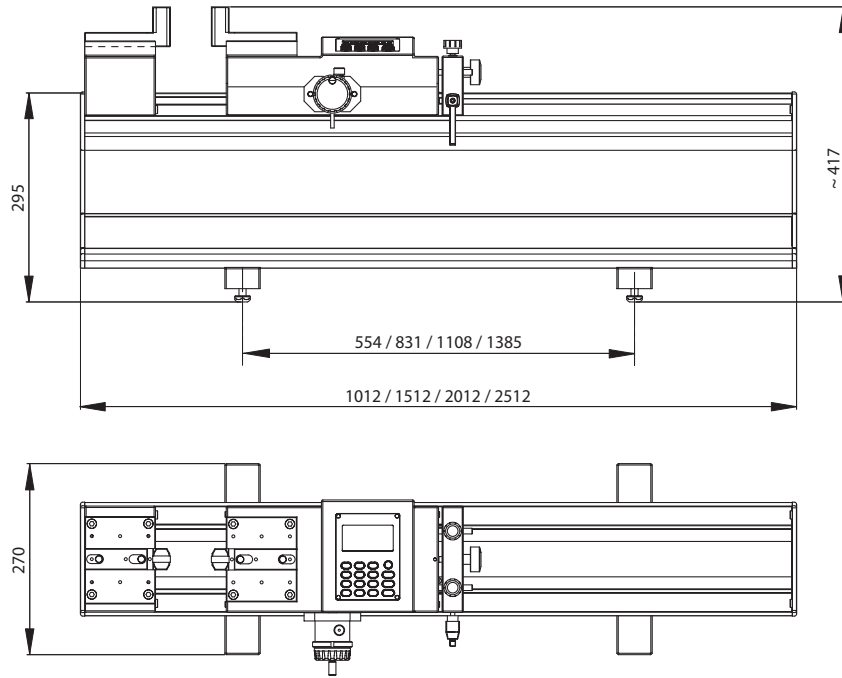

HORIZON GRANITE

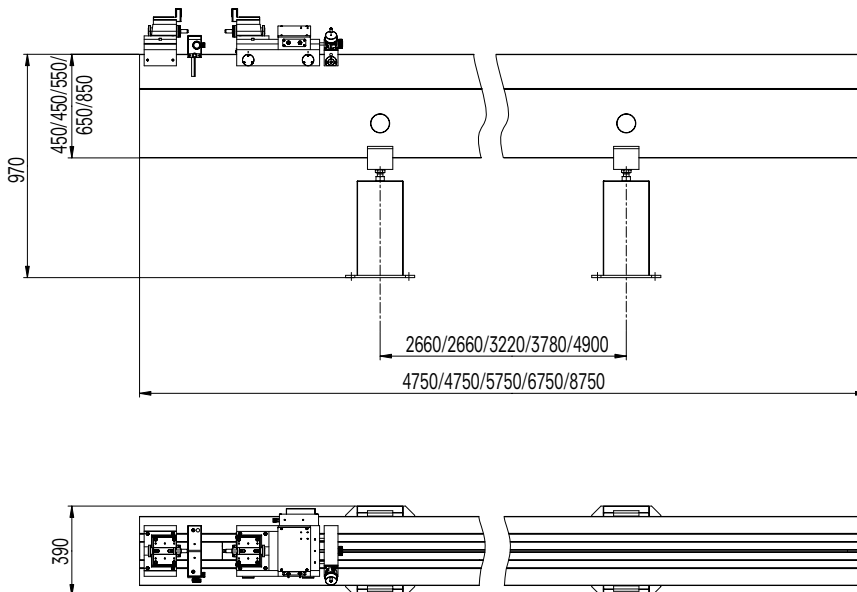

STANDARD INSTRUMENT

The Horizon instruments are supplied as follows:

Instrument according to specifications
Pair of parallel attachments 25 mm (TEL5)
Universal AC adapter (TA-EL-131)
Protection cover (TEL.HO500/1000/1500/2000)
Allen key set (TA-TO-004)
User's manual (750 50 0005 03)
Test certificate

The Horizon Granite instruments are supplied as follows:

Instrument according to specifications
Pair of anvils with tungsten carbide surface (TEL1)
Lapping plate (TA-TO-302)
Protection cover (TEL.HO3000/4000/5000/6000/8000)
Compressed air tubing and air filter
Allen key set (TA-TO-004)
User's manual (750 50 0003 03)
Test certificate

CODE NUMBERS

Horizon		
H501	700 201 10 02	Measuring range 500 mm
H1001	700 201 20 02	Measuring range 1000 mm
H1501	700 201 30 02	Measuring range 1500 mm
H2001	700 201 40 02	Measuring range 2000 mm

Horizon Granite		
HG3000	700 208 60 11	Measuring range 3000 mm
HG4000	700 208 70 11	Measuring range 4000 mm
HG5000	700 208 80 11	Measuring range 5000 mm
HG6000	700 208 90 11	Measuring range 6000 mm
HG8000	700 208 110 11	Measuring range 8000 mm

HORIZON + Granite

APPLICATIONS

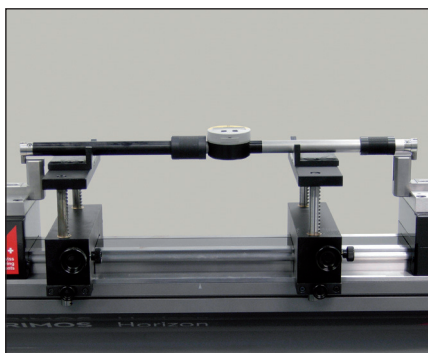

Setting of 2-point internal and external comparative measuring equipment (TEL5/TELMA7/TELMN7.2)

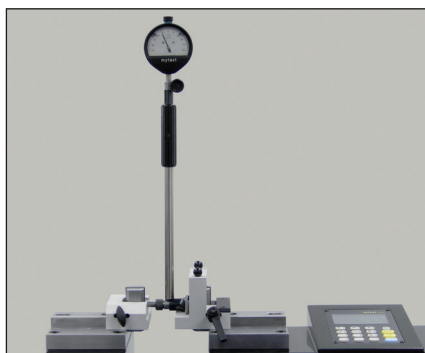

Setting of 2-point bore gauges (TEL5/TA-SU-301)

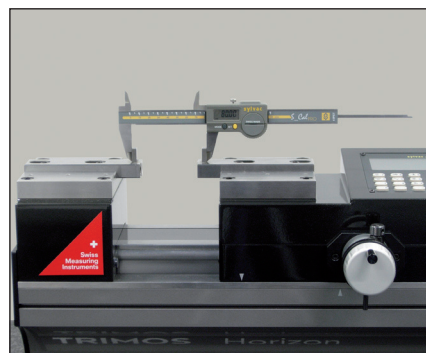

Checking of calipers (TEL5.10)

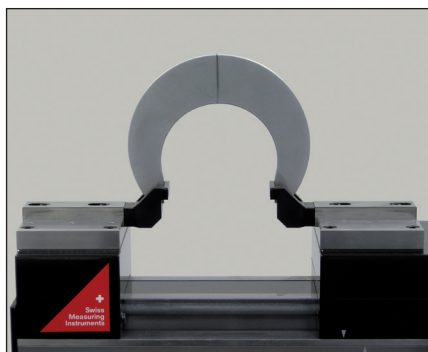

Checking of snap gauges (TELMA8)

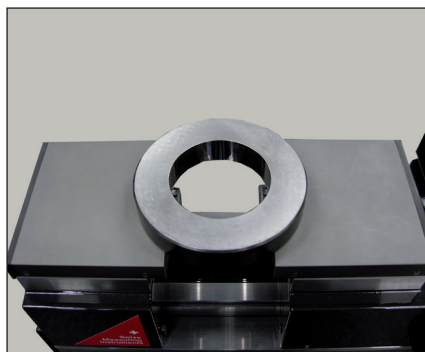

Checking of internal diameter of heavy rings (TEL9/H-5)

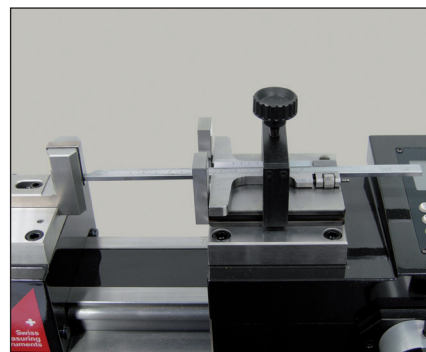

Checking of depth gauges (TULM19/TEL5)



Checking of external micrometers (TEL5/TEL11)

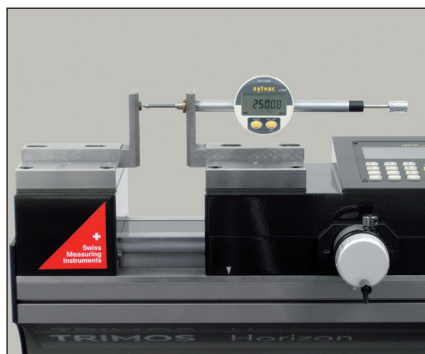

Checking of dial indicators (TEL5CN)

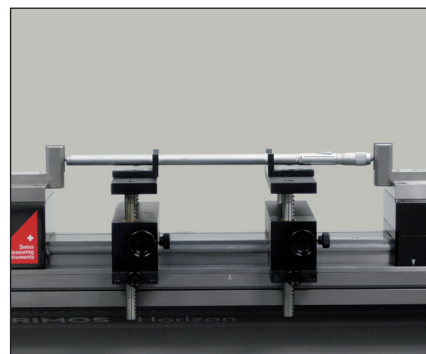

Checking of 2-point internal micrometers (TEL5/TELMA7/TELMN7.2)