

# TVM



# TVM

## INTRODUCTION

The TVM instruments are perfect for height measurements and scribing work and reliable in all kinds of workshop conditions. The result of an unique, compact design of the instrument is great mobility and extreme stability.

Because of its advanced measuring system, the self-contained working time of the TVM is one year. Therefore it can be used for multiple applications in the workshop area. The simplicity of manipulation allows constant change of the user without any time-consuming training.

The success of the TVM among competitive gauges is outstanding. More than 14'000 instruments are in use worldwide.

Three models are available: with application range from 300 to 1000 mm. A large range of accessories for all kinds of measuring applications is available.

---

ROBUST AND COMPACT CONSTRUCTION

---

PERFECT FOR USE IN PRODUCTION AREA

---

ACCURATE AND RELIABLE MEASUREMENTS

---

USER FRIENDLY

---

OPTO-RS232 DATA OUTPUT





---

RECHARGEABLE BATTERY PACK

---

TWO MODELS: CAST IRON BASE OR A GRANITE BASE

## DESCRIPTION

-  Surfaces
-  2 references
-  Internal/external diameters
-  Tolerances
-  Min/Max/Delta

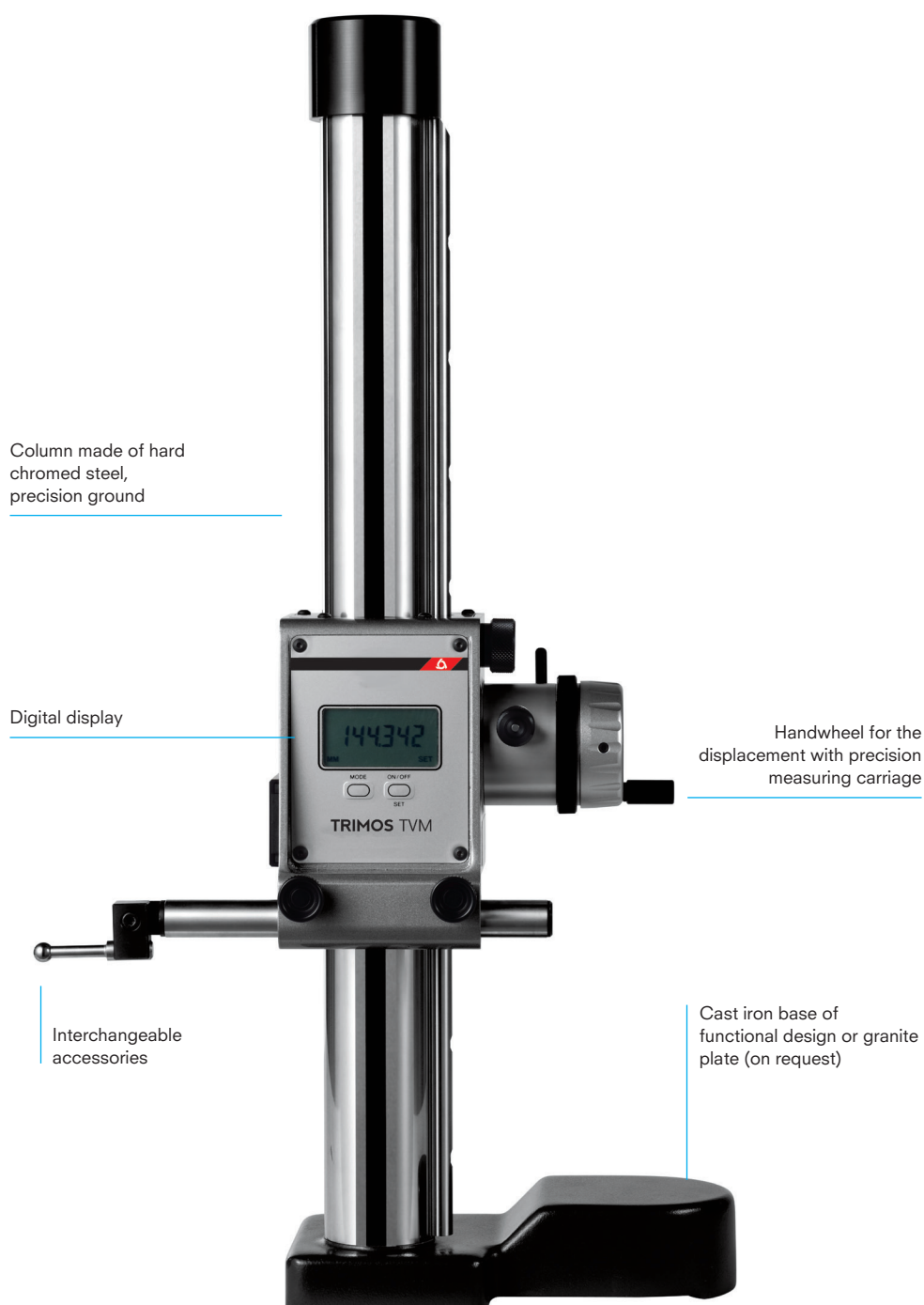

# TVM

## DISPLAY / SOFTWARE

The clearly defined functions of the display unit allow to collect all height measuring values.

- MIN / MAX FUNCTION INDICATOR

---

- 2 REFERENCES

---

- END OF BATTERY LIFE WARNING INDICATION

---

- PRESET SELECTION

---

- MEASURING UNIT (MM / IN) INDICATOR

---

- TOLERANCE MODE INDICATOR

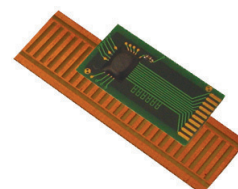
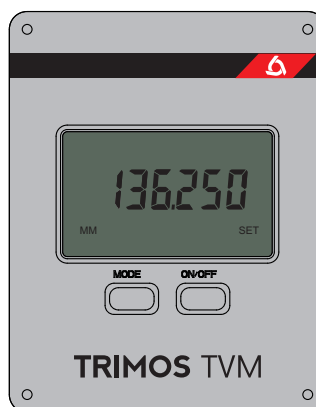

**sylvac** system



## TECHNICAL SPECIFICATIONS

| TVM                                     |         | 302                           | 602      | 1002      |
|---|---------|-------------------------------|----------|-----------|
| Measuring range                         | mm (in) | 320 (12)                      | 620 (24) | 1020 (40) |
| Max. permissible errors <sup>1)</sup>   | mm      | 0.02                          | 0.03     | 0.04      |
| Repeatability (2s) <sup>1)</sup>        | mm      | 0.005                         |          |           |
| Frontal squareness deviation            | mm      | 0.02                          | 0.03     | 0.03      |
| Resolutions                             | mm (in) | 0.01 / 0.001 (.0005 / .00005) |          |           |
| Measuring force                         | N       | 3                             |          |           |
| Max. manual carriage displacement speed | mm/s    | 1500                          |          |           |
| Autonomy                                | h       | 2000                          |          |           |
| Data output                             |         | Opto RS232                    |          |           |
| Operational temperature                 | °C      | +10 ÷ +40                     |          |           |
| Temperature of storage                  | °C      | -10 ÷ +40                     |          |           |
| Weight (cast iron base)                 | kg      | 6                             | 10       | 24        |
| Weight (granite base)                   | kg      | 14                            | 18       |           |

<sup>1)</sup> Values valid with measuring insert and holder (TVM1 / 1.1 / 2) at temperature of 20 ± 0.5°C and relative humidity of 50 ± 5%.

## DIAGRAM

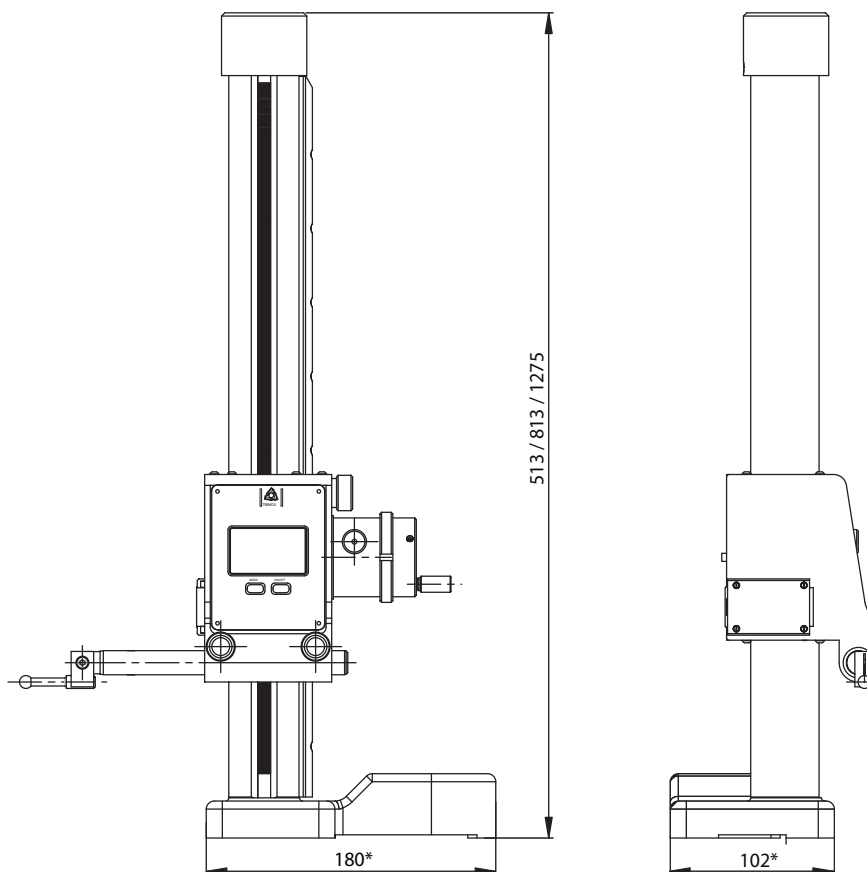

## STANDARD INSTRUMENT

The TVM instruments are supplied as follows:

| TVM 300- 600                                 | TVM1000                                |
|--|--|
| Instrument according to specifications       | Instrument according to specifications |
| Measuring insert and holder (TVM1 / 1.1 / 2) | Measuring insert and holder (TVA1)     |
| Lithium battery, 3 V (BAT-TVM.OPTO)          | Lithium battery, 3 V (BAT-TVM.OPTO)    |
| Protection cover (TVM.HO300/600)             | User's manual (750 50 0018 03)         |
| User's manual (750 50 0018 03)               | Test certificate                       |
| Test certificate                             |  |

## CODE NUMBERS

| Cast iron base               | Granit base                  |                         |
|------------------------------|------------------------------|-------------------------|
| <b>TVM302</b> 700 102 10 11  | <b>TVM302G</b> 700 102 10 14 | Measuring range 300 mm  |
| <b>TVM602</b> 700 102 20 11  | <b>TVM602G</b> 700 102 20 14 | Measuring range 600 mm  |
| <b>TVM1002</b> 700 102 30 11 |                              | Measuring range 1000 mm |

\* TVM 302 and 602 only

# TVM

## APPLICATIONS



Height and depth measurements  
(TVM1/1.1/2)



Diameter measurements (TVM4)



Measuring of centerline distances  
(TVM5)



Scribing (TVM1/TVM3)



Ease of handling